

Series Denison	Description	Size				Mounting		Configuration		Page
		DIN / ISO	¾	1	1¼	1½	SAE61	SAE62	2-port	
	Pressure valves, manual operation									
R5V	Pressure relief function	•	•	•	•	•	•	•	•	9-3
R5U	Pressure unloading function	•	•	•	•	•			•	9-9
R5S	Pressure sequence function	•	•	•		•			•	9-15
R5R	Pressure reducing function	•	•	•		•		•		9-19
	Pressure valves, proportional operation									
R5V*P2	Pressure relief function	•	•	•	•	•	•	•	•	9-25
R5R*P2	Pressure reducing function	•	•	•		•		•		9-31
	Directional seat valves									
D5S		•	•	•	•	•		•	•	9-35
	Flow valves									
F5C	Throttle valves, proportional	•	•	•		•		•		9-49
R5A	2-way pressure compensator	•	•	•		•		•		9-53
R5P	3-way pressure compensator	•	•	•	•	•			•	9-57
	Check valves									
C5V	Direct operated	•	•	•	•	•	•	•		9-65
C5P	Pilot and direct operated	•	•	•		•		•		9-69
	Accessories									
	Bolt kits, flanges, plugs									9-73

More pressure valves are presented in the following chapters:

- Chapter 7: Sandwich Valves
- Chapter 8: Slip-In Cartridge Valves
- Chapter 9: SAE Flange Valves
- Chapter 10: Valves for Pipe Mounting

Characteristics

Pilot operated pressure relief valves series R5V have a similar design to the subplate mounted R4V series. The SAE flanges allow to mount the valves directly on the outlet flanges of pumps or inlet flanges of actuators to achieve a very compact design.

Valves with SAE flanges can also be bolted together to combine functions without the need of a manifold block.

Features

- Pilot operated with manual adjustment
- R5V with 2-port body
 - 3 sizes (SAE ¾", 1", 1¼")
 - SAE61 flange
- R5V with 3-port body
 - 4 sizes (SAE ¾", 1", 1¼", 1½")
 - SAE61 and SAE62 flange
- 3 pressure stages
- 3 adjustment modes
 - Hand knob
 - Acorn nut with lead seal
 - DIN lock
- With optional vent function

Pilot Operated Pressure Relief Valve Series R5V (Denison)



R5V 2-port



R5V 3-port

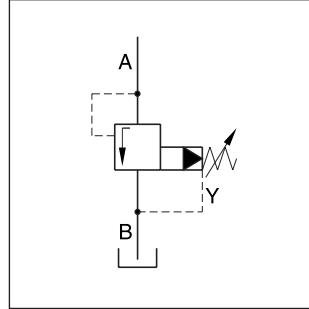

R5V 2-port

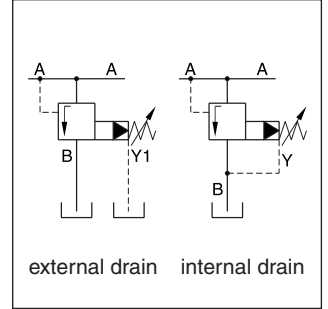

R5V 3-port

R5V 2-port

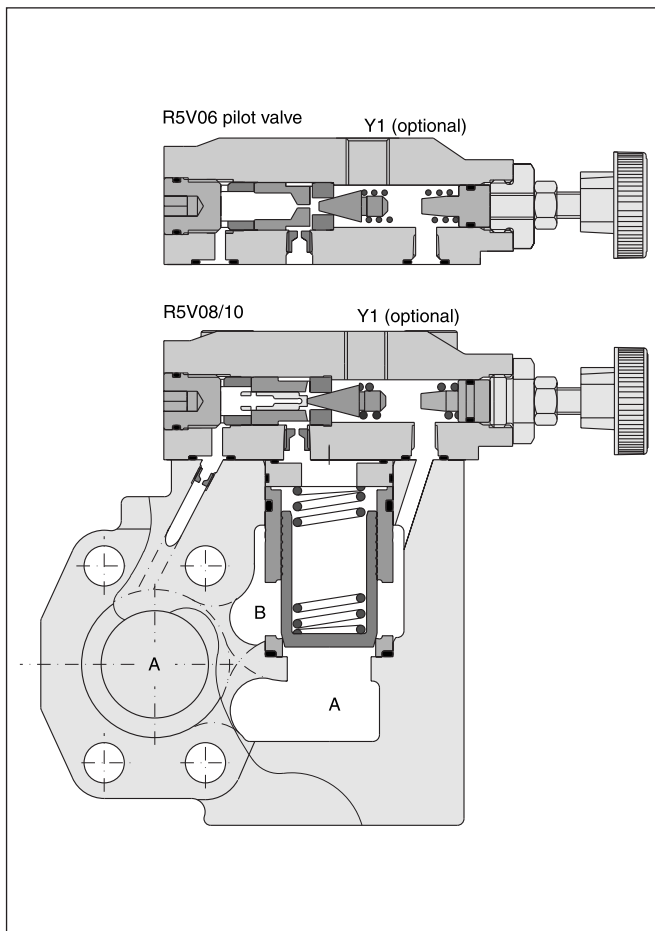

R5V 3-port

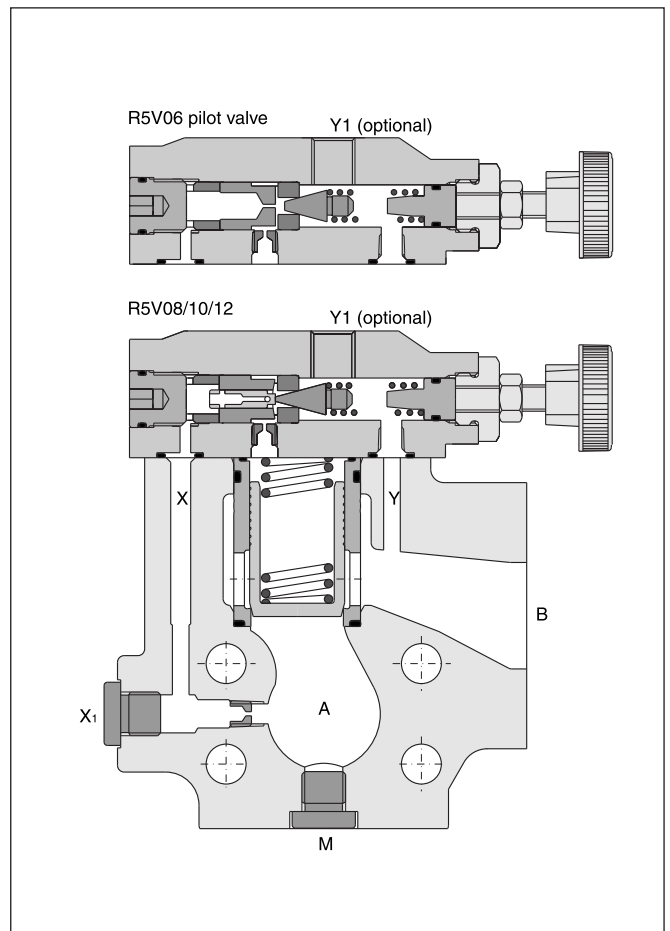

R5V_UK.INDD RH

Ordering Code

Ordering code

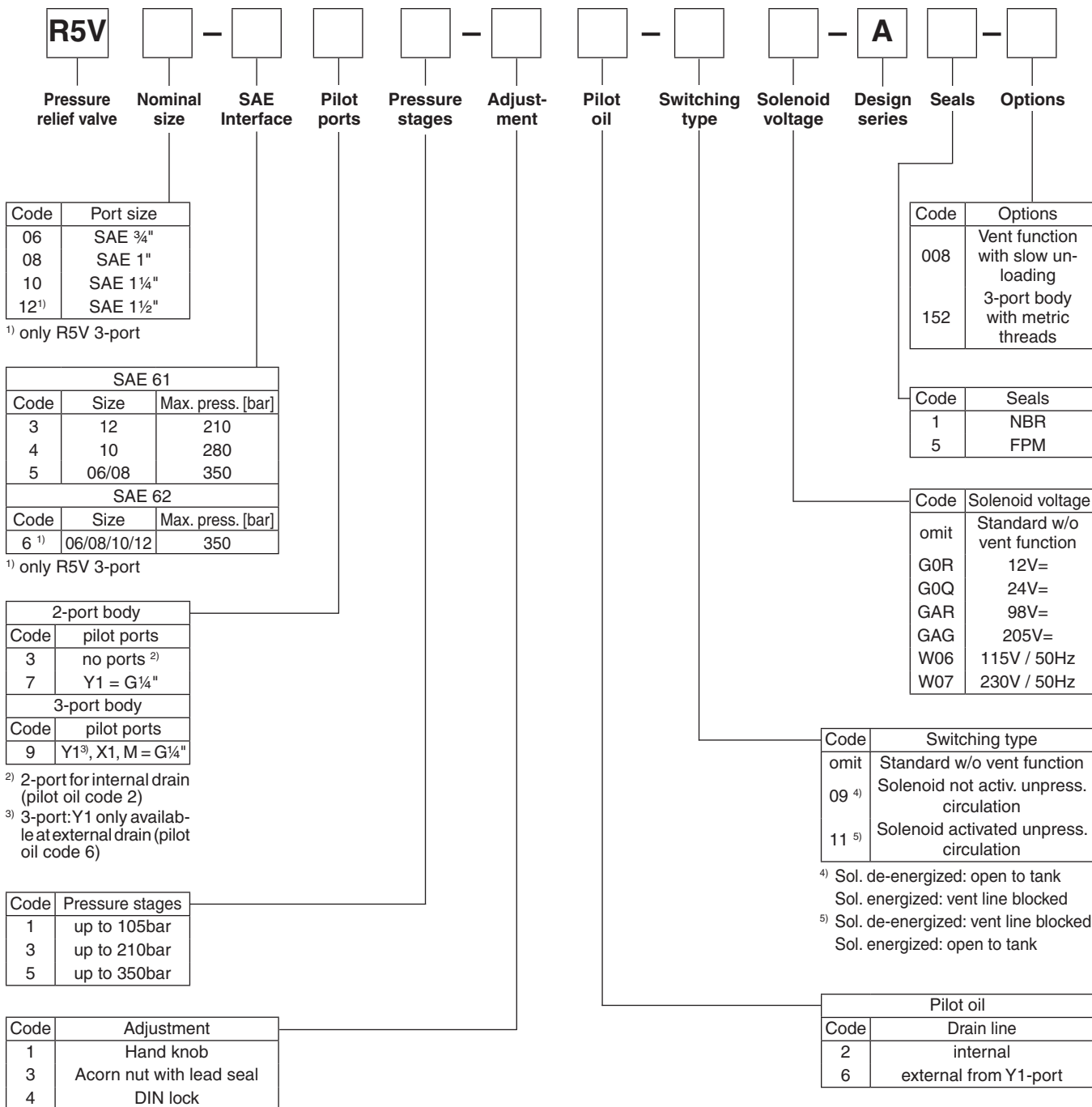

Further options on request

Technical data

General		06 (¾")	08 (1")	10 (1¼")	12 (1½")		
Size		06 (¾")	08 (1")	10 (1¼")	12 (1½")		
Mounting		Flanged according to SAE 61 and SAE 62					
Mounting position		unrestricted					
Ambient temperature	[°C]	-20...+50					
Weight	R5V 2port	4.0	4.6	5.9	—		
	R5V 3port	3.6	4.6	5.2	8.0		
Hydraulic							
Max. operating pressure	[bar]						
	SAE61 Ports A, B	350	350	280	210		
	Port Y1	30	30	30	30		
	SAE62 Ports A, B	350	350	350	350		
	Port Y1	30	30	30	30		
Pressure stages	[bar]	105, 210, 350					
Nominal flow	[l/min]	90	300	600	600		
Fluid		Hydraulic oil as per DIN 51524...525					
Fluid temperature	[°C]	-20...+80					
Viscosity permitted	[cSt] [mm²/s]	10...650					
Viscosity recommended	[cSt] [mm²/s]	30					
Filtration		ISO 4406 (1999) 18/16/13 (acc. NAS 1638: 7)					
Electrical (solenoid)							
Duty ratio	[%]	100					
Solenoid connection		Connector as per EN175301-803					
Protection class		IP65 in accordance with EN 60529 (plugged and mounted)					
	Code	G0R	G0Q	GAR	GAG	W06	W07
Supply voltage	[V]	12V =	24V =	98V =	205V =	150 at 50Hz	230 at 50Hz
Tolerance supply voltage	[%]	+5...-10	+5...-10	+5...-10	+5...-10	+5...-10	+5...-10
Power consumption	hold	31	31	31	31	78	78
	in rush	31	31	31	31	264	264
Response time	[ms]	Energized / De-energized AC: 20/18 , DC: 46/27					
Max. switching frequency		AC: up to 7200, DC: up to 16000 switchings/hour					
Coil insulation class		H (180 °C)					



p/Q performance curve

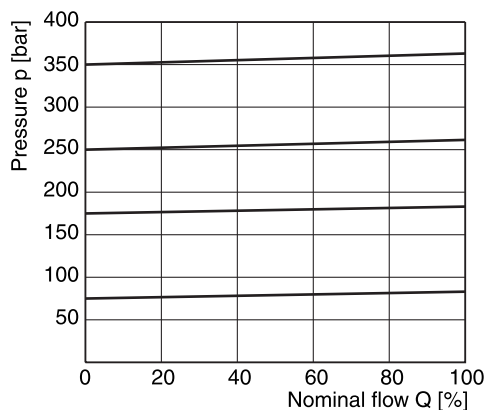

Minimum pressure curve

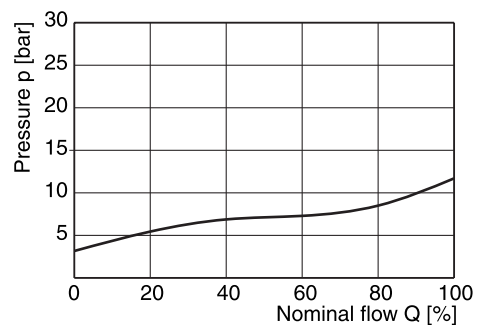

The performance curves are measured with external drain.
For internal drain the tank pressure has to be added to curve.

Pilot Operated Pressure Relief Valve Series R5V (Denison)

Dimensions

Dimensions R5V 2-port

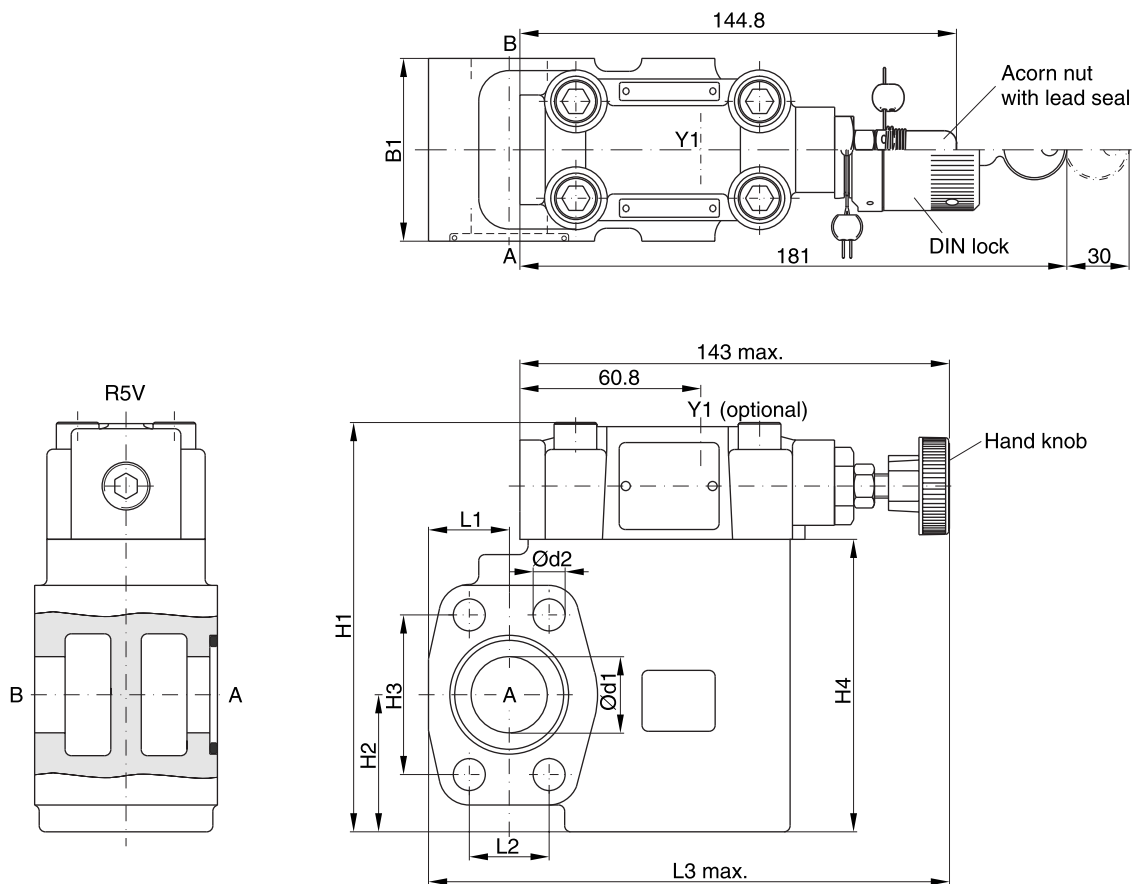

SAE61

NG	B1	H1	H2	H3	H4	L1	L2	L3	d1	d2
06	60	131.6	37	47.6	90	24.6	22.2	152	19	10.5
08	60	137.6	45	52.4	96	26.5	26.2	171	25	10.5
10	75	150.6	48	58.7	109	34.0	30.2	179	32	12.5

Port	Function	Port size		
		R5V06	R5V08	R5V10
A	Pressure	3/4" SAE61	1" SAE61	1 1/4" SAE61
B	Tank	3/4" SAE61	1" SAE61	1 1/4" SAE61
Y1	External drain	G1/4"		

R5V_UK.INDD RH



Dimensions

**Pilot Operated Pressure Relief Valve
Series R5V (Denison)**

Dimensions R5V 3-port

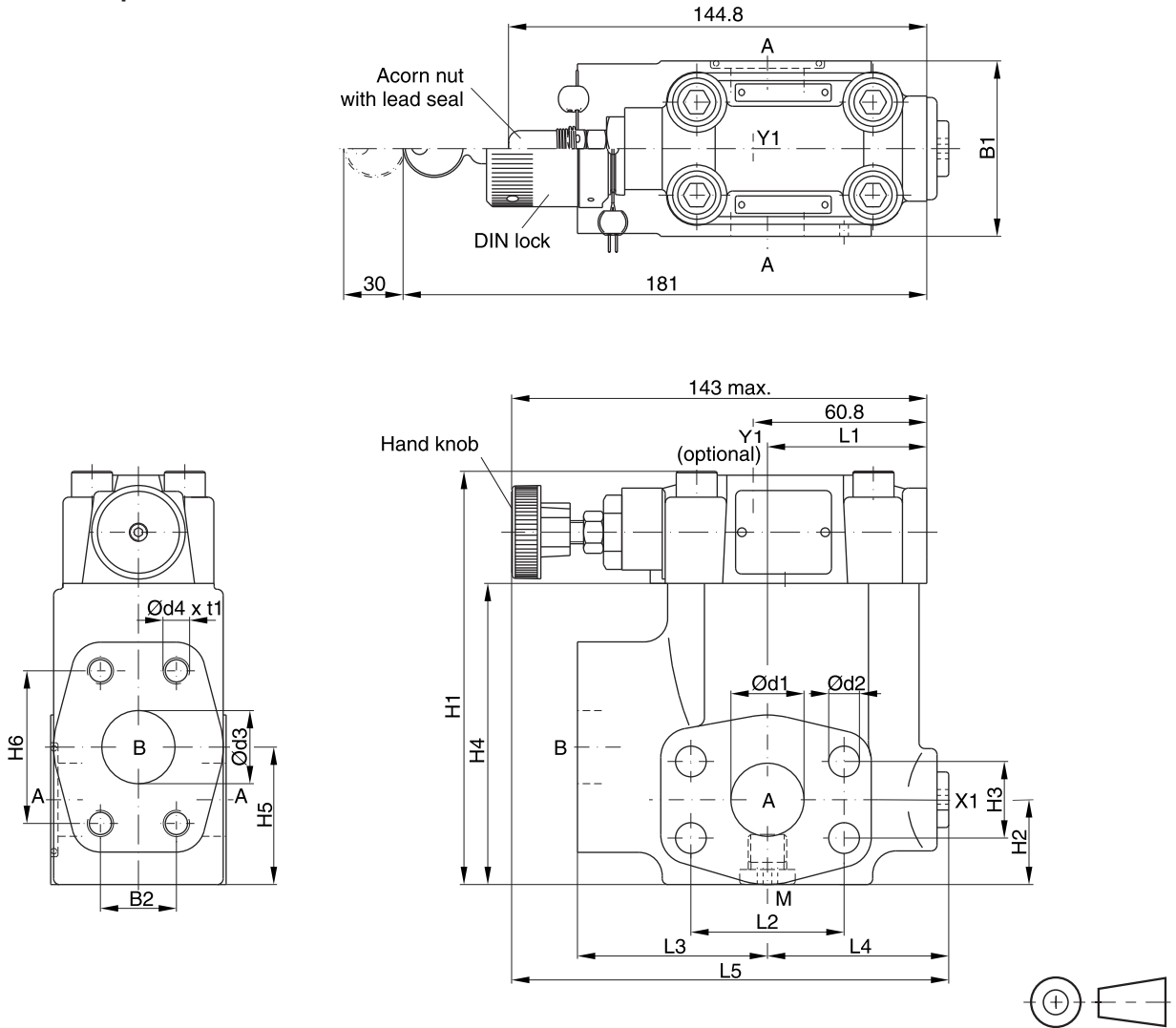

SAE61

NG	B1	B2	H1	H2	H3	H4	H5	H6	L1	L2	L3	L4	L5	d1	d2	d3	d4 (option 152)	t1
06	60	22.2	119	28	22.2	81	41.6	47.6	50.3	47.6	63	56	152	19	10.5	19	3/8"-16 UNC (M10)	20
08	60	26.2	141	29	26.2	103	47	52.4	55.8	52.4	65	58	149	25	10.5	25	3/8"-16 UNC (M10)	23
10	75	30.2	151	34.5	30.2	113	64	58.7	57.8	58.7	61	62	150.5	32	12.5	32	7/16"-14 UNC (M12)	22
12	80	35.7	178	34	35.7	140	73	69.8	37.3	69.8	92.5	55.2	171.2	38	13.5	38	1/2"-13 UNC (M12)	27

SAE62

NG	B1	B2	H1	H2	H3	H4	H5	H6	L1	L2	L3	L4	L5	d1	d2	d3	d4 (option 152)	t1
06	60	23.8	119	28	23.8	81	41.6	50.8	50.3	50.8	63	56	152	19	10.5	19	3/8"-16 UNF (M10)	20
08	60	27.8	141	29	27.8	103	47	57.2	55.8	57.2	65	58	149	25	12.5	25	7/16"-14 UNC (M12)	22
10	75	31.8	151	34.5	31.8	113	64	66.7	57.8	66.7	61	62	150.5	32	13.5	32	1/2"-13 UNC (M12)	24
12	80	36.5	178	34	36.5	140	73	79.4	37.3	79.4	92.5	55.2	171.2	38	17	38	5/8"-11 UNC (M16)	33

Port	Function	Port size			
		R5V06	R5V08	R5V10	R5V12
A (2)	Pressure	3/4" SAE61/62	1" SAE61/62	1 1/4" SAE61/62	1 1/2" SAE61/62
B	Tank	3/4" SAE61/62	1" SAE61/62	1 1/4" SAE61/62	1 1/2" SAE61/62
X1	External pilot port ¹⁾	G 1/4"			
Y1	External drain	G 1/4"			
M	Pressure gauge	G 1/4"			

¹⁾ closed when supplied

R5V_UK.INDD RH

Dimensions

Dimensions R5V with vent function

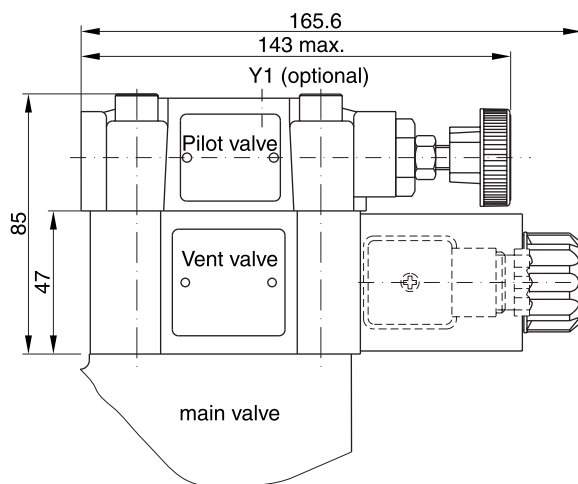
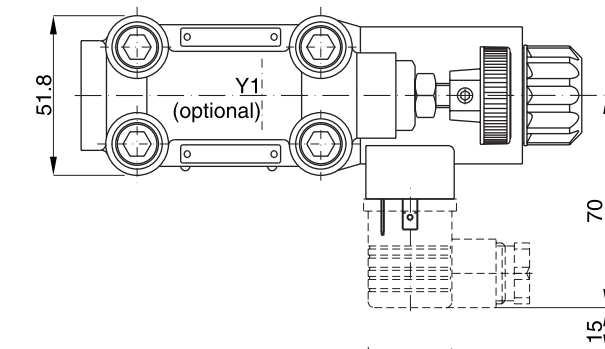

9

Code	R5V 2-port		R5V 3-port	
	Internal drain	External drain	Internal drain	External drain
11				
09				

R5V_UK.INDD RH



Characteristics

Pilot operated pressure unloading valves series R5U have a similar design to the subplate mounted R4U series. The SAE flanges allow to mount the valve directly on the outlet flanges of pumps.

A typical application is the unloading of a pump in an accumulator circuit. The combination of an R5U, C5V and R5V on a double pump generates a high pressure / low pressure pump system without the need of a manifold block or piping between the valves.

Features

- Pilot operated unloading valve
- 3-port body with SAE61 flange
- 4 sizes (SAE 3/4", 1", 1 1/4", 1 1/2")
- 3 pressure stages
- 3 adjustment modes
 - Hand knob
 - Acorn nut with lead seal
 - DIN lock
- With optional vent function

Pilot Operated Pressure Unloading Valve Series R5U (Denison)

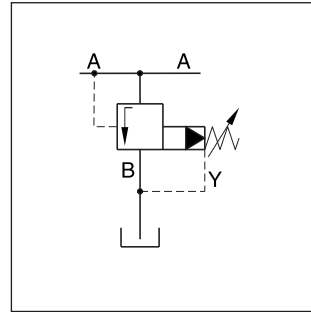

R5U 3-port internal drain

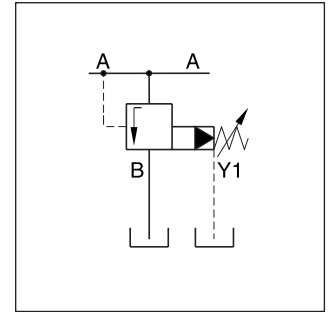

R5U 3-port external drain

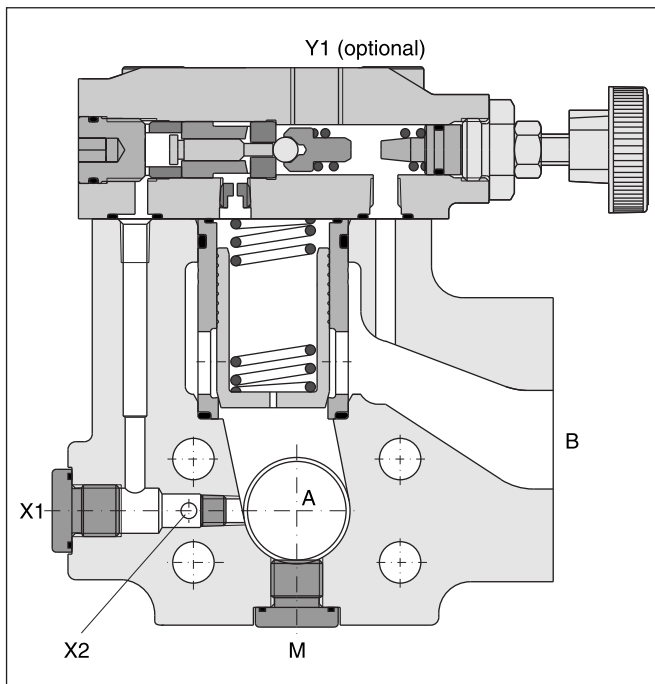

High pressure / low pressure system

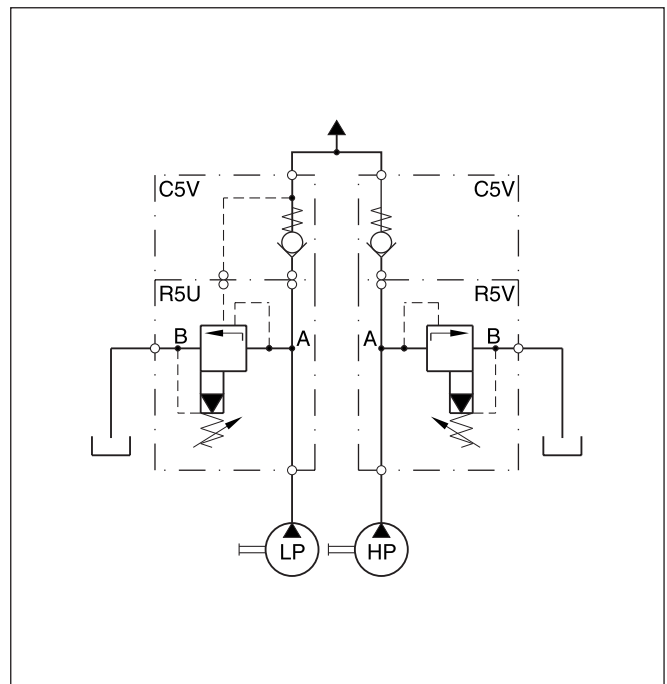

R5U_UK.INDD RH



Ordering Code

Ordering code

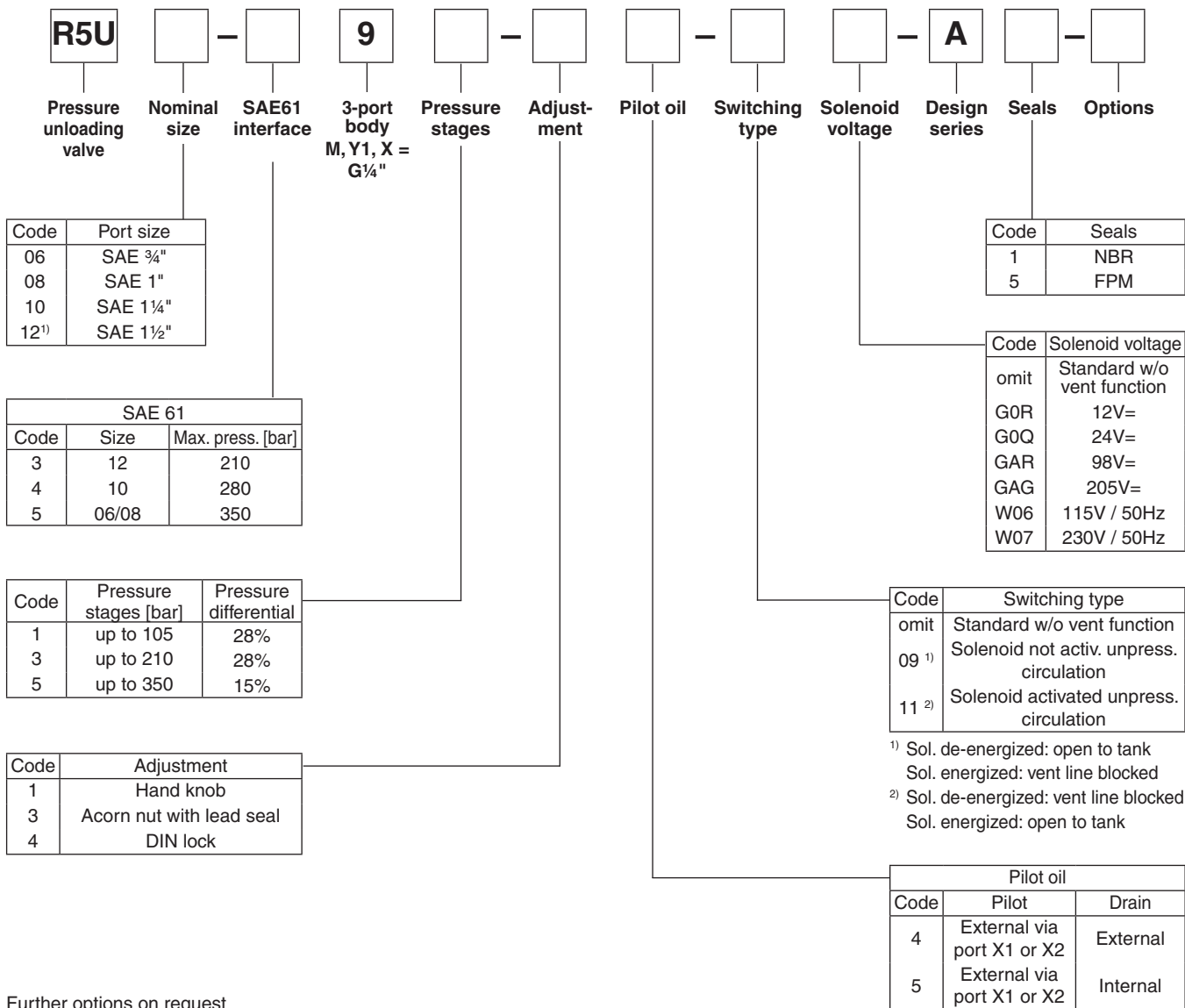

Further options on request

Technical data

General		06 (¾")	08 (1")	10 (1¼")	12 (1½")		
Size							
Mounting		Flanged according to SAE 61					
Mounting position		unrestricted					
Ambient temperature	[°C]	-20...+50					
Weight	[kg]	3.6	4.6	5.2	8.0		
Hydraulic							
Max. operating pressure	[bar]						
	Ports A, B, X	350	350	280	210		
	Ports Y, Y1	30	30	30	30		
Pressure stages	[bar]	105, 210, 350					
Nominal flow	[l/min]	90	300	600	600		
Fluid		Hydraulic oil as per DIN 51524...525					
Fluid temperature	[°C]	-20...+80					
Viscosity permitted	[cSt] [mm²/s]	10...650					
Viscosity recommended	[cSt] [mm²/s]	30					
Filtration		ISO 4406 (1999) 18/16/13 (acc. NAS 1638: 7)					
Electrical							
Duty ratio	[%]	100					
Solenoid connection		Connector as per EN175301-803					
Protection class		IP65 in accordance with EN 60529 (plugged and mounted)					
		G0R	G0Q	GAR	GAG	W06	W07
Direct current		12V = +5...-10 31 31	24V = +5...-10 31 31	98V = +5...-10 31 31	205V = +5...-10 31 31	150 at 50Hz +5...-10 78 264	230 at 50Hz +5...-10 78 264
Response time	[ms]	Energized / De-energized AC: 20/18 , DC: 46/27					
Max. switching frequency		AC: up to 7200, DC: up to 16000 switchings/hour					
Coil insulation class		H (180 °C)					

p/Q performance curve

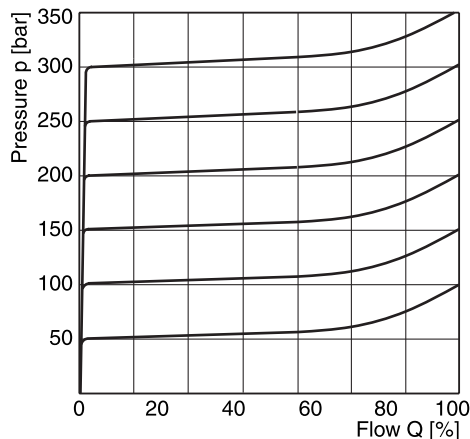

Minimum pressure curve

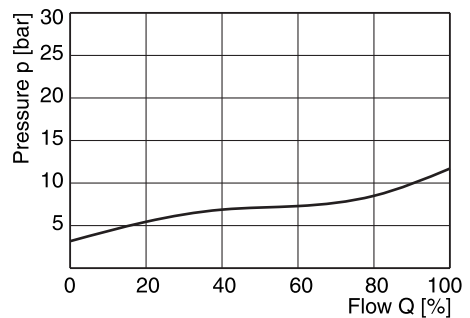

The performance curves are measured with external drain.
For internal drain the tank pressure has to be added to curve.

Dimensions

Dimensions R5U

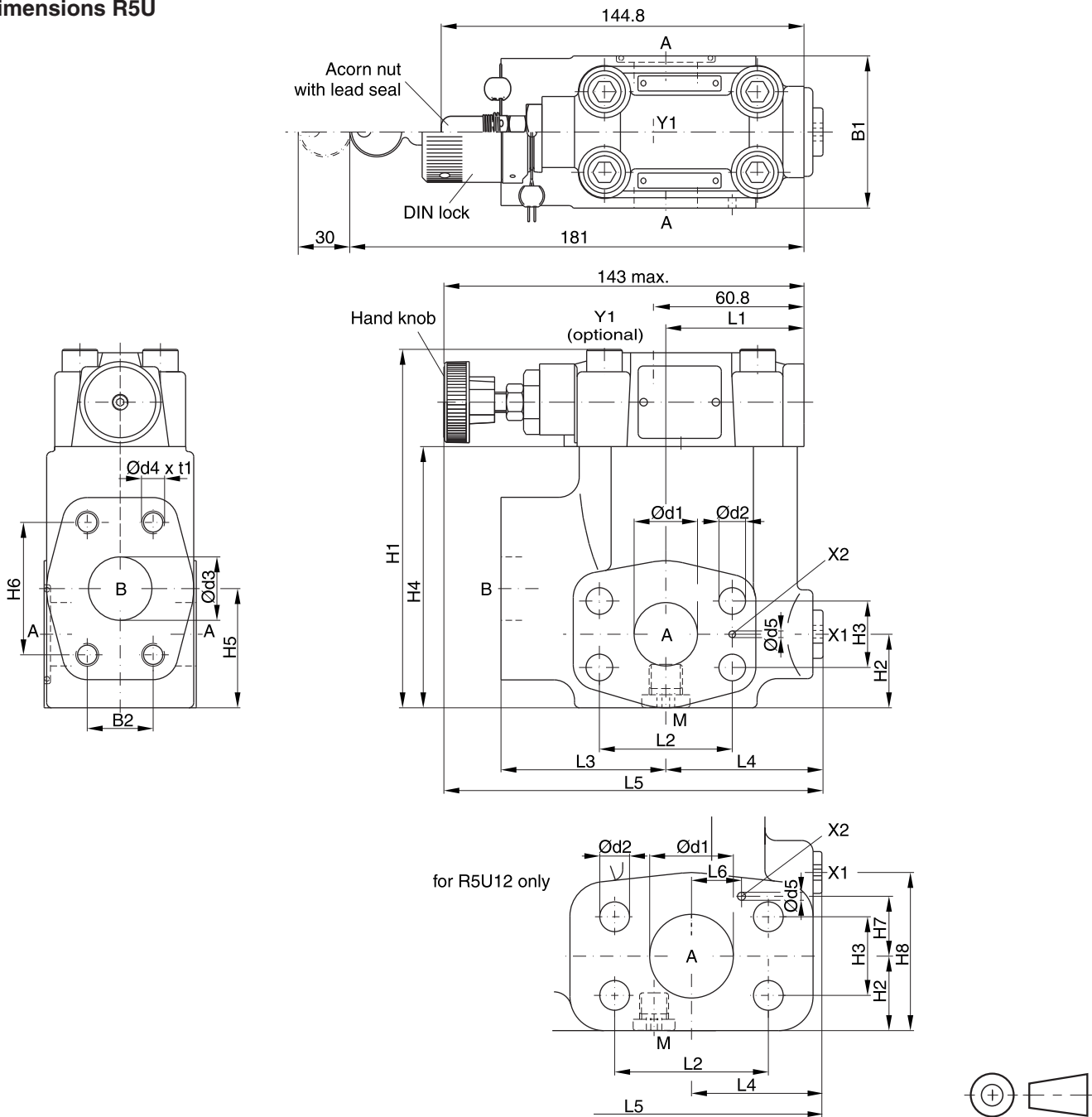

9

NG	B1	B2	H1	H2	H3	H4	H5	H6	L1	L2	L3	L4	L5	d1	d2	d3	d4	t1	d5	L6	H7	H8
06	60	22.2	119	28	22.2	81	41.6	47.6	50.3	47.6	63	56	152	19	10.5	19	3/8"-16 UNC	20	3.0	-	-	-
08	60	26.2	141	29	26.2	103	47	52.4	55.8	52.4	65	58	149	25	10.5	25	3/8"-16 UNC	23	3.0	-	-	-
10	75	30.2	151	34.5	30.2	113	64	58.7	57.8	58.7	61	62	150.5	32	12.5	32	7/16"-14 UNC	22	3.0	-	-	-
12	80	35.7	178	34	35.7	140	73	69.8	37.3	69.8	92.5	55.2	171.2	38	13.5	38	1/2"-13 UNC	27	3.0	34.9	27.2	73

Port	Function	Port size			
		R5U06	R5U08	R5U10	R5U12
A (2)	Pressure	3/4" SAE61	1" SAE61	1 1/4" SAE61	1 1/2" SAE61
B	Tank	3/4" SAE61	1" SAE61	1 1/4" SAE61	1 1/2" SAE61
X1	External pilot port ¹⁾	G 1/4"			
Y1	External drain	G 1/4"			
M	Pressure gauge	G 1/4"			

¹⁾ closed when supplied

R5U_UK.INDD RH

Dimensions R5U with vent function

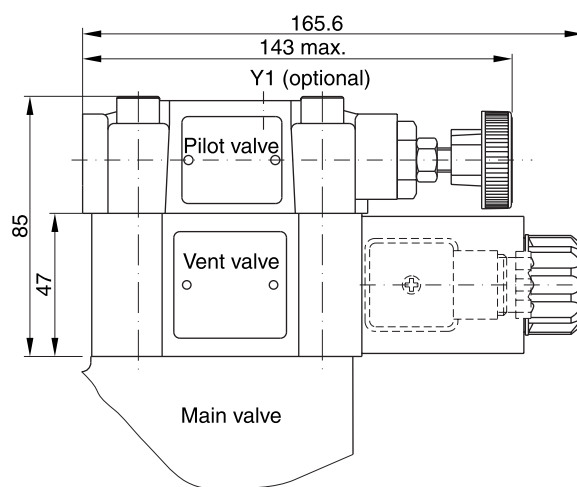
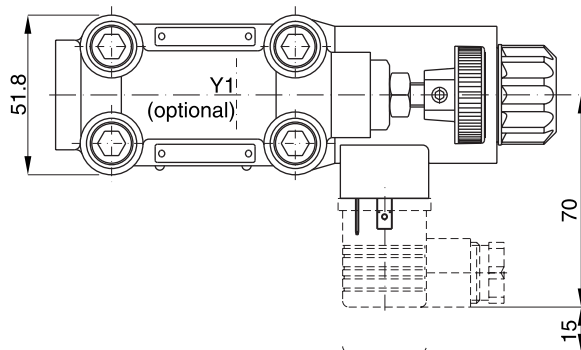

Code	Internal drain	External drain
11		
09		

R5U_UK.INDD RH

Characteristics

**Pilot Operated Sequence Valve
Series R5S (Denison)**

Pilot operated sequence valves series R5S have a similar design to the subplate mounted R4S series. The SAE flanges allow to mount the valve directly on the inlet flanges of actuators or outlet flanges of pumps to achieve a very compact design.

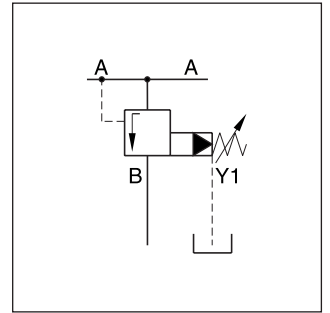

Features

- Pilot operated with manual adjustment
- 3-port body with SAE61 flange
- 3 sizes (SAE 3/4", 1", 1 1/4")
- 3 pressure stages
- 2 adjustment modes
 - Hand knob
 - Acorn nut with lead seal

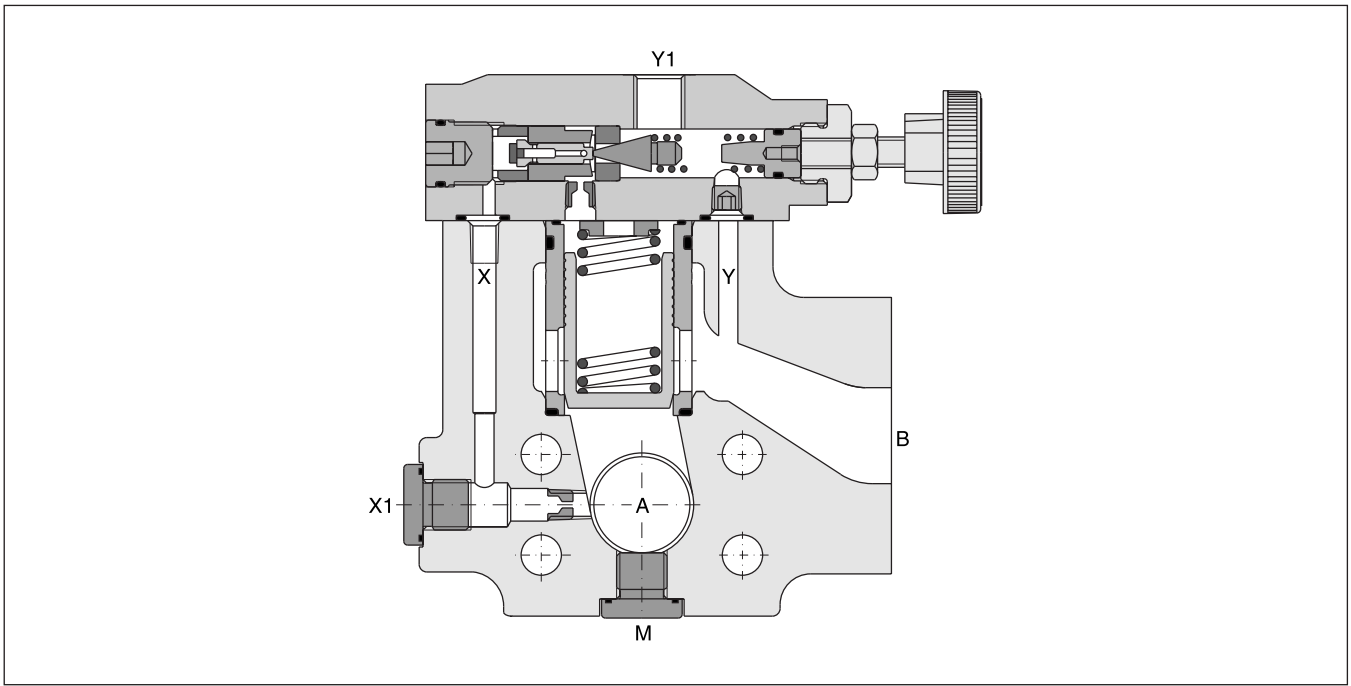

Ordering Code / Technical Data

Ordering code

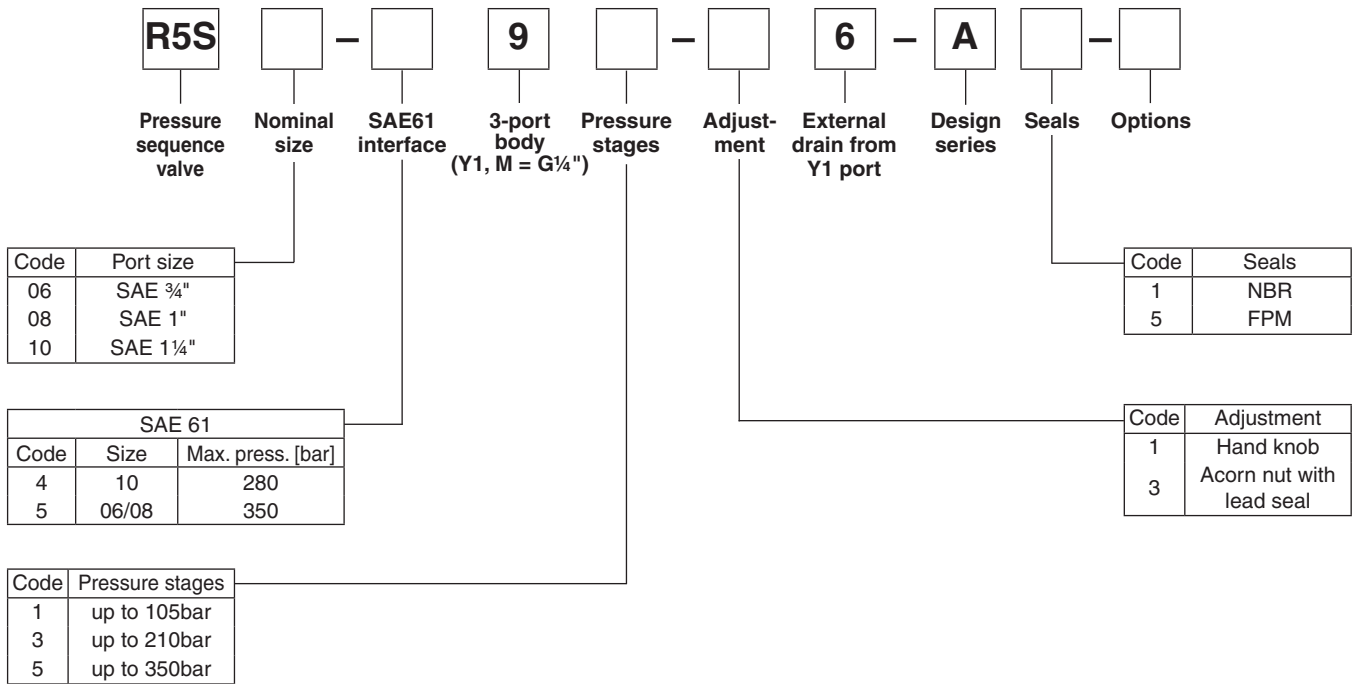

Further options on request

9

Technical Data

General		06 (3/4")	08 (1")	10 (1 1/4")
Size				
Mounting		Flanged according to SAE 61		
Mounting position		unrestricted		
Ambient temperature	[°C]	-20...+50		
Weight	[kg]	3.6	4.6	5.2
Hydraulic				
Max. operating pressure	[bar]			
Ports A, B		350	350	280
Ports Y, Y1		30	30	30
Pressure stages	[bar]	105, 210, 350		
Nominal flow	[l/min]	90	300	600
Fluid		Hydraulic oil as per DIN 51524...525		
Fluid temperature	[°C]	-20...+80		
Viscosity permitted	[cSt] [mm ² /s]	10...650		
Viscosity recommended	[cSt] [mm ² /s]	30		
Filtration		ISO 4406 (1999) 18/16/13 (acc. NAS 1638: 7)		

Typical pressure characteristics at closing point

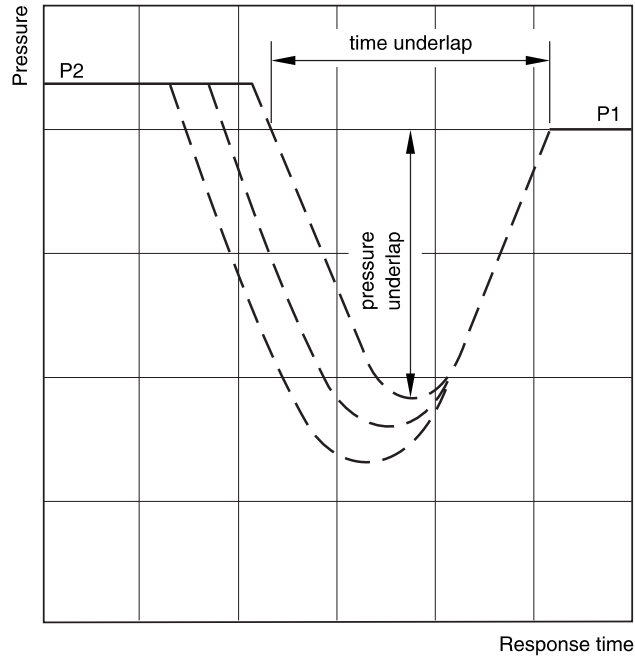

P1 = setting pressure
P2 = operating pressure

Time and pressure underlap depend on the characteristics of the specific system.

Dimensions

**Pilot Operated Sequence Valve
Series R5S (Denison)**

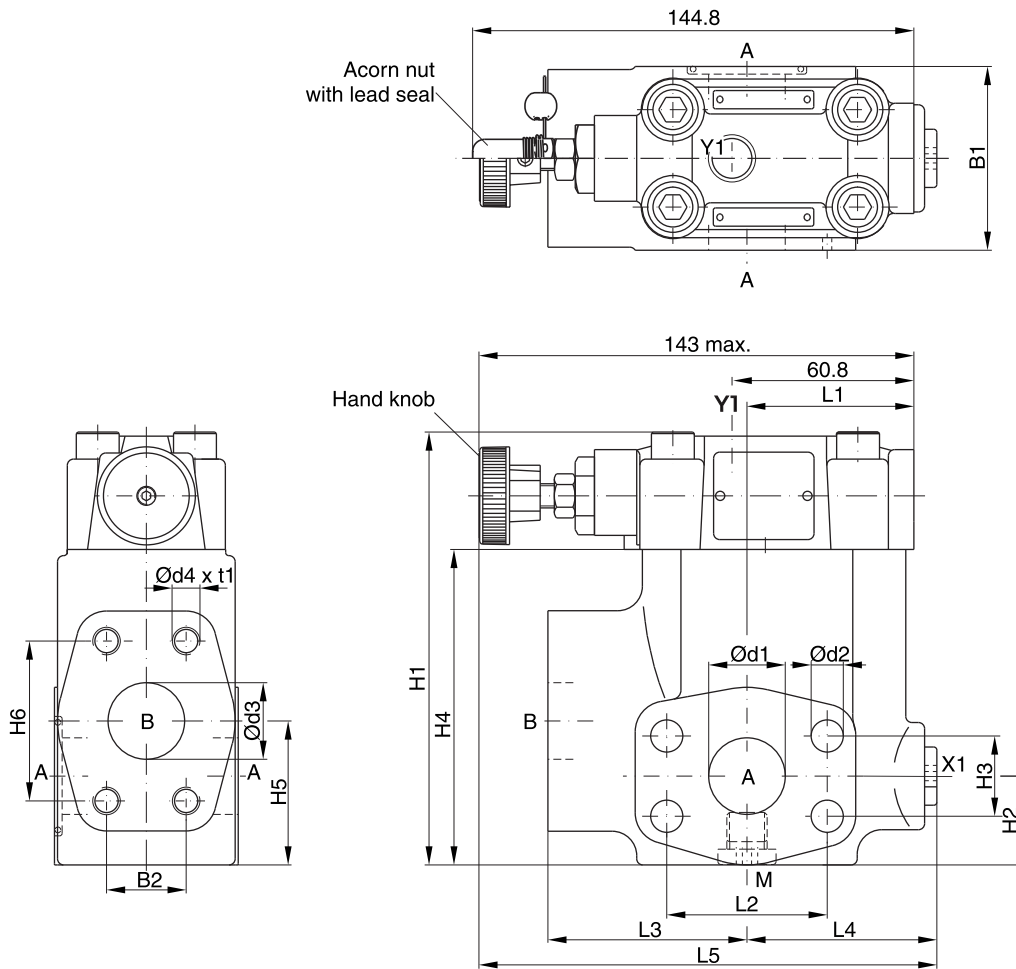

SAE61

NG	B1	B2	H1	H2	H3	H4	H5	H6	L1	L2	L3	L4	L5	d1	d2	d3	d4 (option 152)	t1
06	60	22.2	119	28	22.2	81	41.6	47.6	50.3	47.6	63	56	152	19	10.5	19	3/8"-16 UNC (M10)	20
08	60	26.2	141	29	26.2	103	47	52.4	55.8	52.4	65	58	149	25	10.5	25	3/8"-16 UNC (M10)	23
10	75	30.2	151	34.5	30.2	113	64	58.7	57.8	58.7	61	62	150.5	32	12.5	32	7/16"-14 UNC (M12)	22

Port	Function	Port size		
		R5S06	R5S08	R5S10
A (2)	Pressure	3/4" SAE61	1" SAE61	1 1/4" SAE61
B	Secondary port	3/4" SAE61	1" SAE61	1 1/4" SAE61
X1	External pilot port ¹⁾		G 1/4"	
Y1	External drain		G 1/4"	
M	Pressure gauge		G 1/4"	

¹⁾ closed when supplied

R5S_UK.INDD RH



Characteristics

Pilot operated pressure reducing valves series R5R have a similar design as the subplate mounted R4R series. The SAE flanges allow to mount the valves directly on the inlet flanges of actuators to achieve a very compact design.

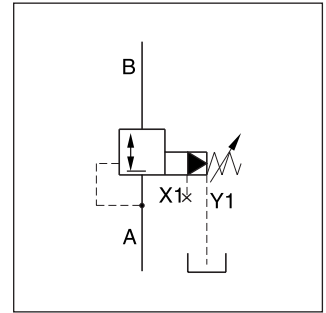

Features

- Pilot operated with manual adjustment
- Normally closed to avoid unintended motion
- 2-port body with SAE61 flange
- 3 sizes (SAE 3/4", 1", 1 1/4")
- 3 pressure stages
- 3 adjustment modes
 - Hand knob
 - Acorn nut with lead seal
 - DIN lock
- With optional vent function

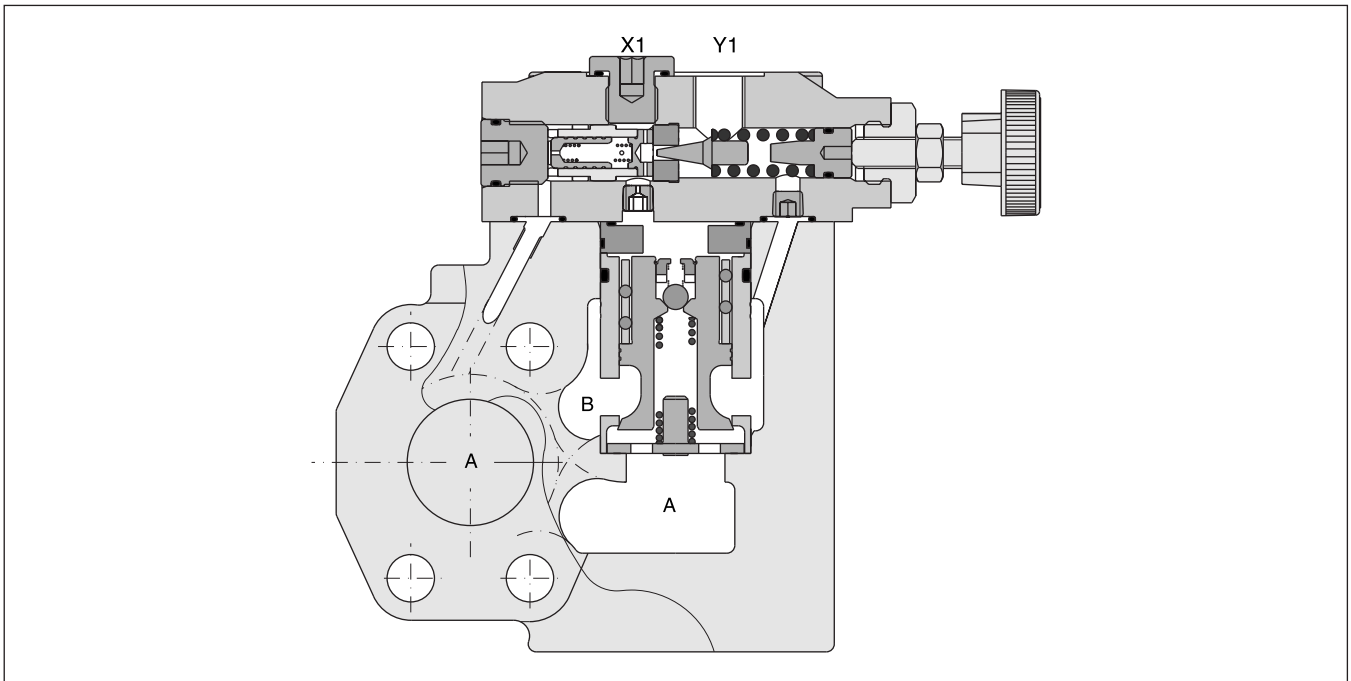

Ordering Code

Ordering code

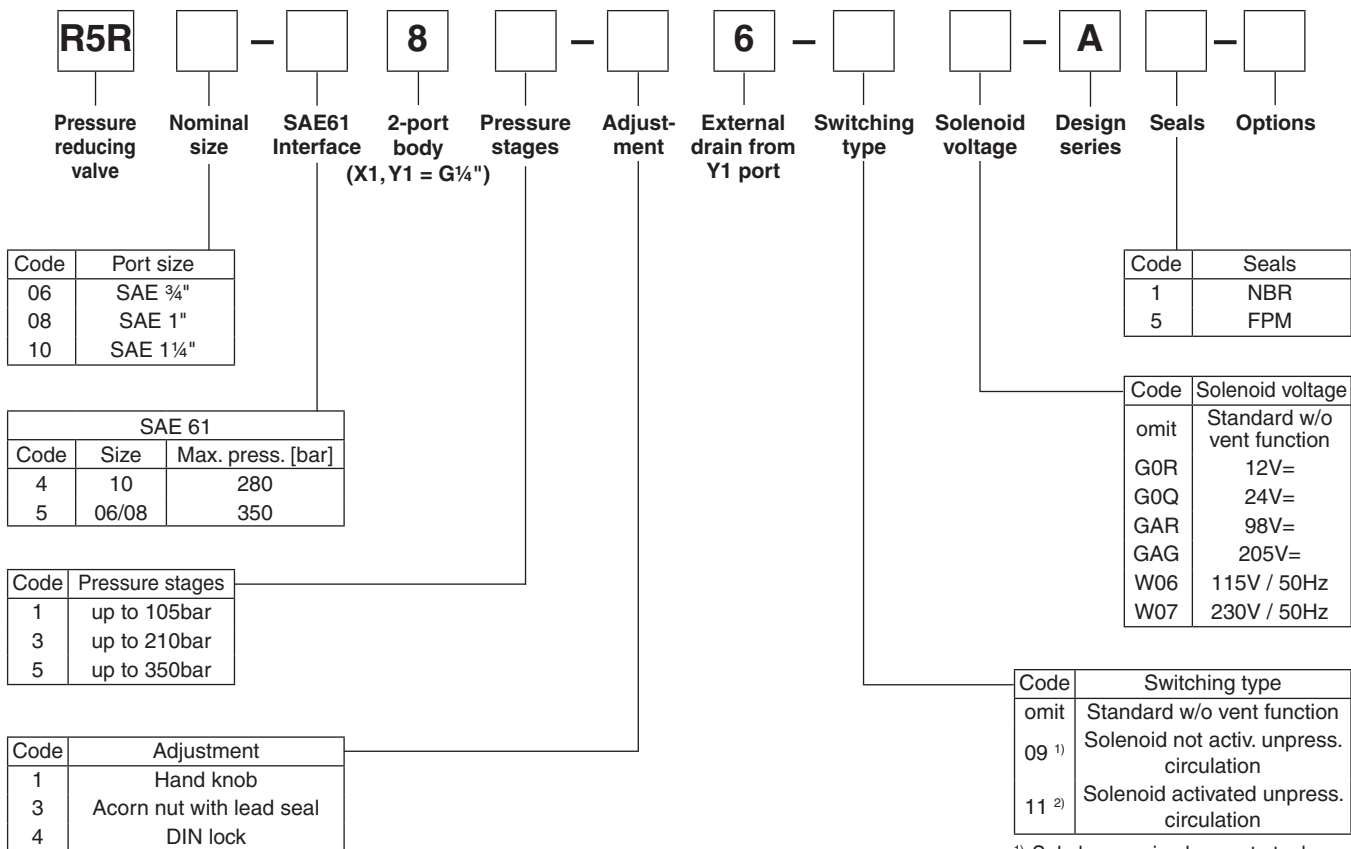

¹⁾ Sol. de-energized: open to tank
Sol. energized: vent line blocked
²⁾ Sol. de-energized: vent line blocked
Sol. energized: open to tank

Further options on request

Technical Data

General		06	08	10			
Size							
Mounting		Flanged according to SAE 61					
Mounting position		unrestricted					
Ambient temperature	[°C]	-20...+50					
Weight	[kg]	4.0	4.6	5.9			
Hydraulic							
Max. operating pressure	[bar]						
	Ports A, B, X1	350	350	280			
	Port Y1	30	30	30			
Pressure stages	[bar]	105, 210, 350					
Nominal flow	[l/min]	90	300	600			
Fluid		Hydraulic oil as per DIN 51524...525					
Fluid temperature	[°C]	-20...+80					
Viscosity permitted	[cSt] [mm ² /s]	10...650					
Viscosity recommended	[cSt] [mm ² /s]	30					
Filtration		ISO 4406 (1999) 18/16/13 (acc. NAS 1638: 7)					
Electrical (solenoid)							
Duty ratio	[%]	100					
Solenoid connection		Connector as per EN175301-803					
Protection class		IP65 in accordance with EN 60529 (plugged and mounted)					
		G0R	G0Q	GAR	GAG	W06	W07
		12V =	24V =	98V =	205V =	150 at 50Hz	230 at 50Hz
Direct current		+5...-10	+5...-10	+5...-10	+5...-10	+5...-10	+5...-10
		31	31	31	31	78	78
		31	31	31	31	264	264
Response time	[ms]	Energized / De-energized AC: 20/18 , DC: 46/27					
Max. switching frequency		AC: up to 7200, DC: up to 16000 switchings/hour					
Coil insulation class		H (180 °C)					

Reduced pressure pA versus flow Q

Series R5R06 ¹⁾

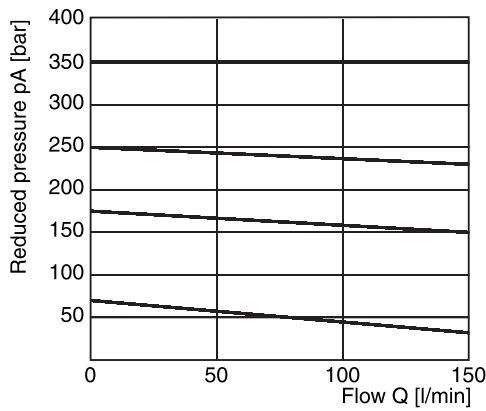

Minimum pressure curve

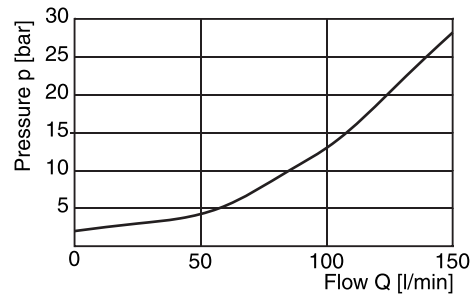

Reduced pressure pA versus flow Q

Series R5R08 ¹⁾

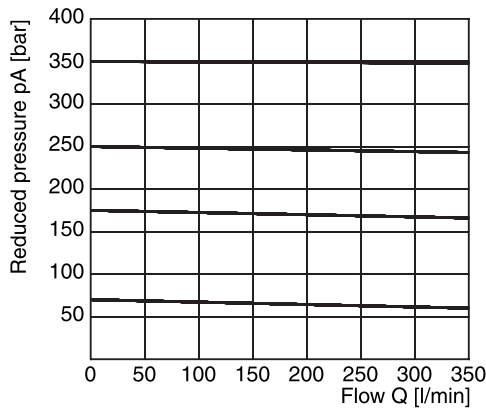

Minimum pressure curve

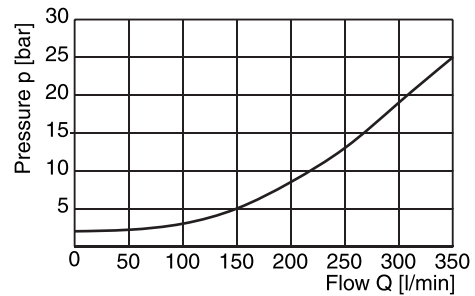

9

Reduced pressure pA versus flow Q

Series R5R10 ¹⁾

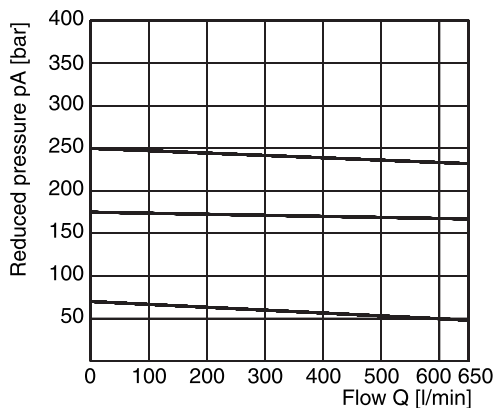

Minimum pressure curve

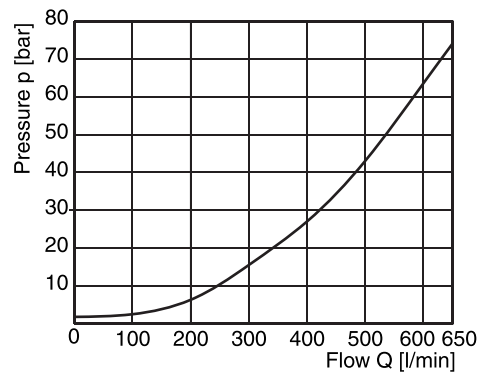

¹⁾ Measured at 350 bar primary pressure pB.

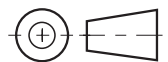
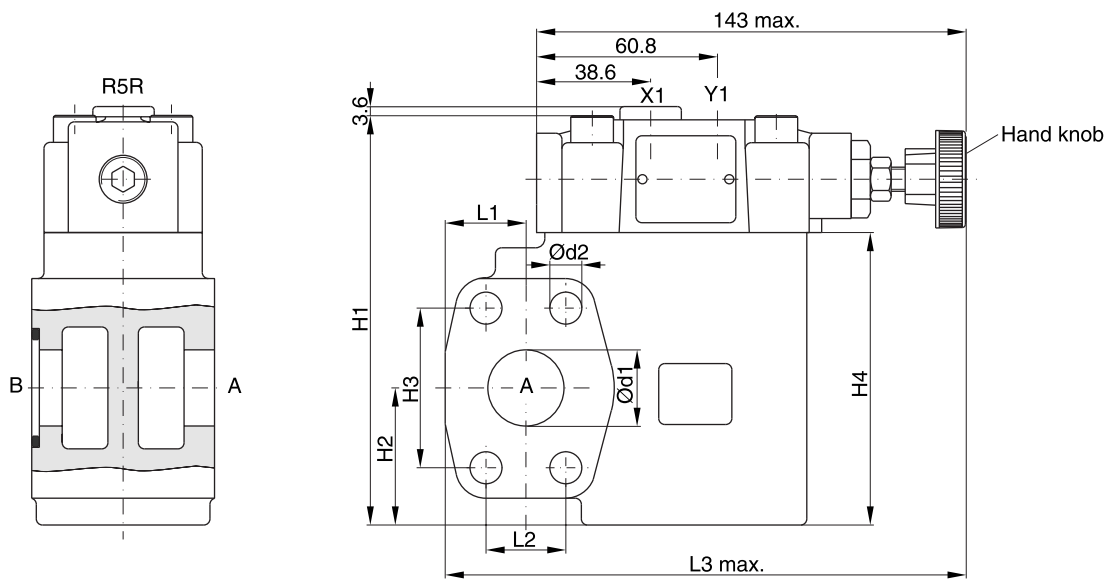
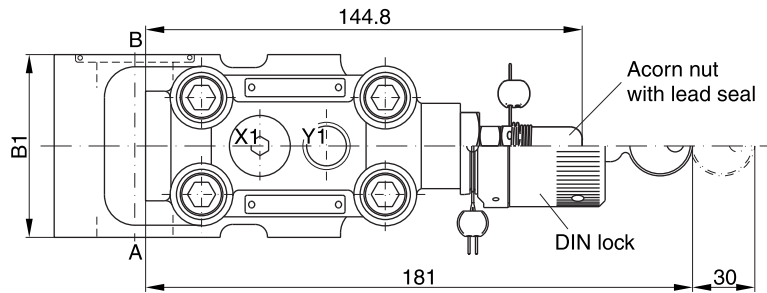

NG	B1	H1	H2	H3	H4	L1	L2	L3	d1	d2
06	60	131.6	37	47.6	90	24.6	22.2	152	19	10.5
08	60	137.6	45	52.4	96	26.5	26.2	171	25	10.5
10	75	150.6	48	58.7	109	34.0	30.2	179	32	12.5

Port	Function	Port size		
		R5R06	R5R08	R5R10
B	Inlet pressure	3/4" SAE61	1" SAE61	1 1/4" SAE61
A	Reduced outlet pressure	3/4" SAE61	1" SAE61	1 1/4" SAE61
Y1	External drain	G 1/4"		
X1	Pressure gauge	G 1/4"		

R5R_UK.INDD RH

Dimensions

Dimensions R5R with vent function

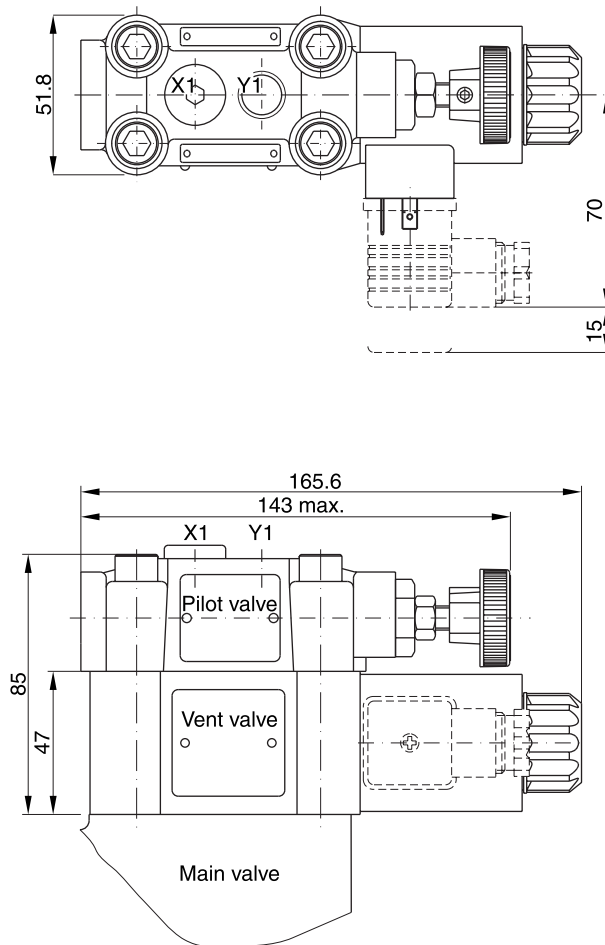

9

Code	External drain
11	
09	

Characteristics

Proportional pressure relief valves series R5V*P2 are based on the mechanical adjusted series R5V. The additional proportional unit between the mechanical pilot valve and the main stage allows continuous pressure adjustment.

The optimum performance can be achieved in combination with the digital amplifier module PCD00A-400.

Features

- Pilot operated with proportional solenoid
- Continuous adjustment by proportional solenoid
- R5V with 2-port body
 - 3 sizes (SAE 3/4", 1", 1 1/4")
 - SAE61 flange
- R5V with 3-port body
 - 4 sizes (SAE 3/4", 1", 1 1/4", 1 1/2")
 - SAE61 and SAE62 flange
- 3 pressure stages
- With mechanical maximum pressure adjustment

Pilot Operated Pressure Relief Valve Series R5V*P2 (Denison)



R5V*P2 2-port



R5V*P2 3-port

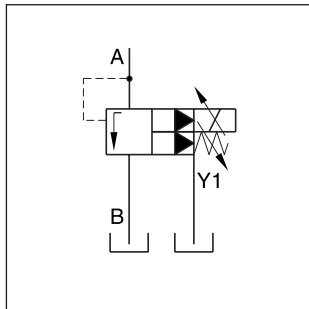

R5V*P2 2-port

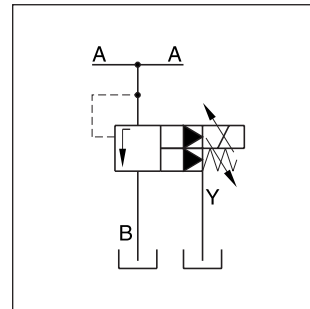

R5V*P2 3-port

R5V*P2 2-port

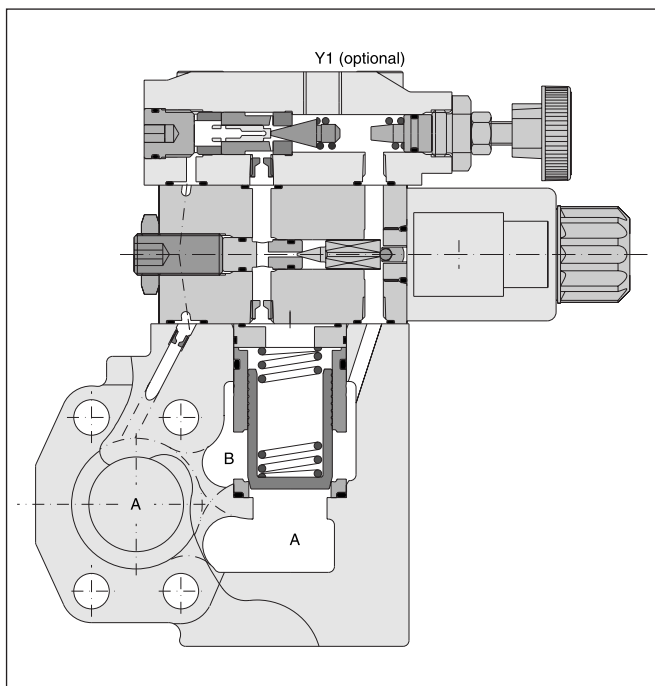

R5V*P2 3-port

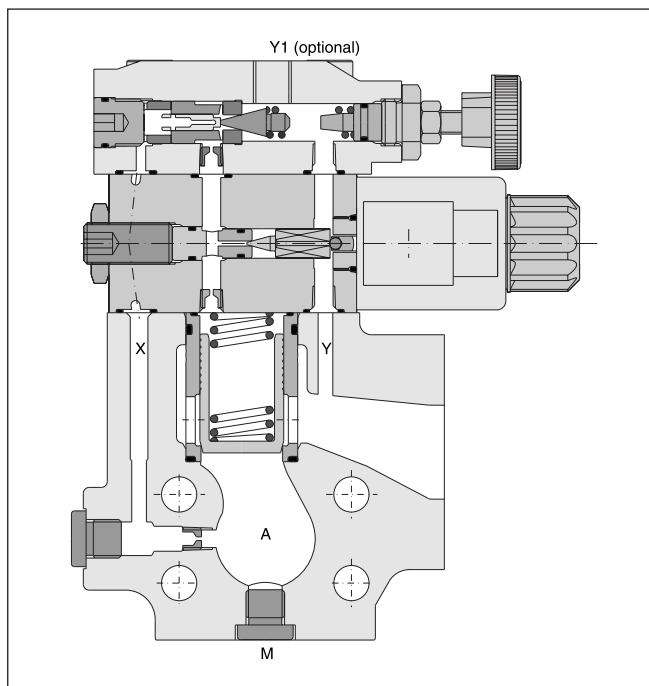

R5VP2_UK.INDD RH

Pilot Operated Pressure Relief Valve Series R5V*P2 (Denison)

Ordering Code

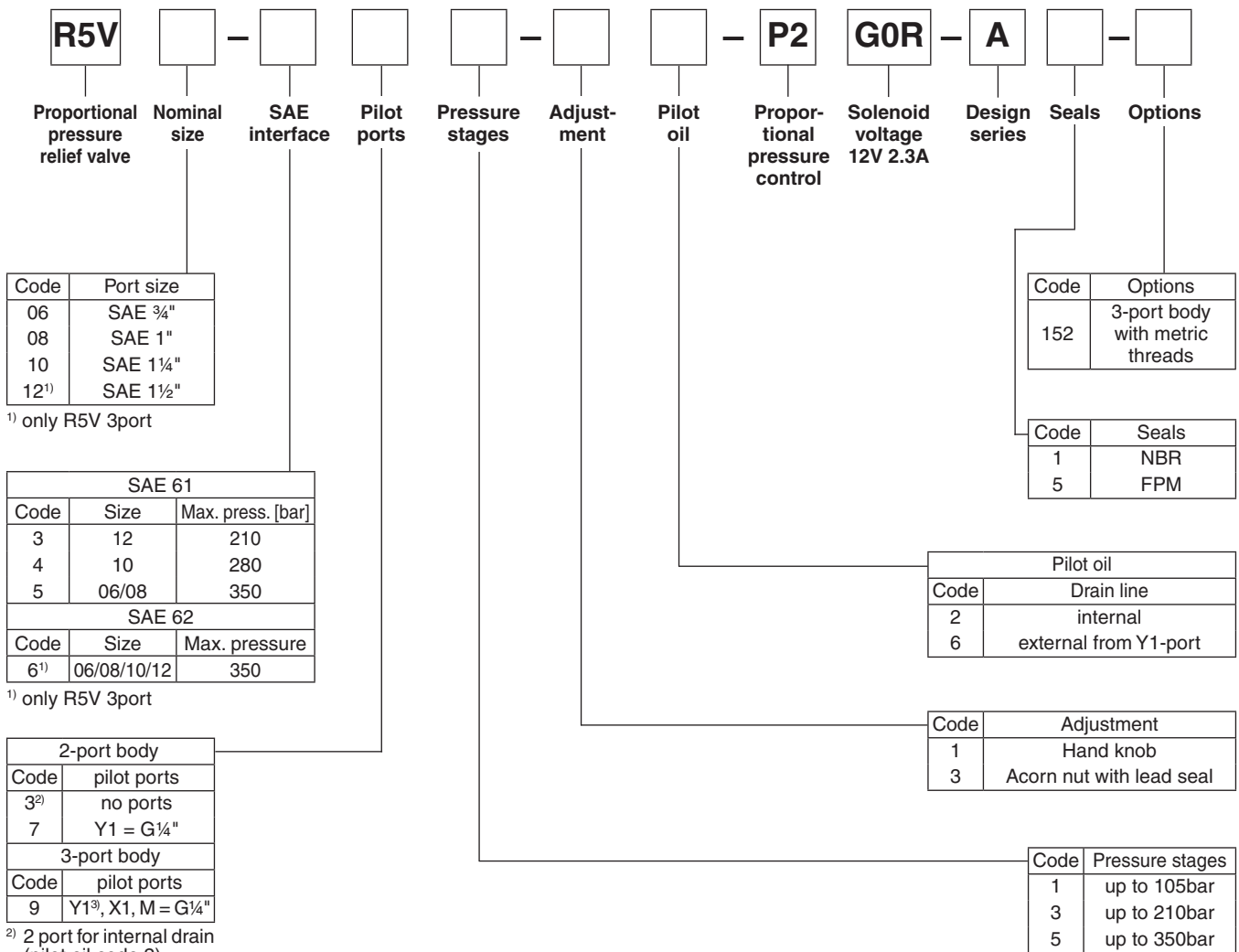

9

Technical Data

General			06 (¾")	08 (1")	10 (1¼")	12 (1½")
Size						
Mounting			Flanged according to SAE 61 (size 12 = SAE 62)			
Mounting position			unrestricted			
Ambient temperature		[°C]	-20...+50			
Weight	R5V 2port	[kg]	5.8	6.4	7.7	—
	R5V 3port	[kg]	5.4	6.4	7.0	9.8
Hydraulic						
Max. operating pressure		[bar]				
	SAE61	Ports A, B	350	350	280	210
		Port Y1	30	30	30	30
	SAE62	Ports A, B	350	350	350	350
		Port Y1	30	30	30	30
Pressure stages		[bar]	105, 210, 350			
Nominal flow		[l/min]	90	300	600	600
Fluid			Hydraulic oil as per DIN 51524...525			
Fluid temperature		[°C]	-20...+80			
Viscosity permitted		[cSt] [mm²/s]	10...650			
Viscosity recommended		[cSt] [mm²/s]	30			
Filtration			ISO 4406 (1999) 18/16/13 (acc. NAS 1638: 7)			
Electrical (proportional solenoid)						
Duty ratio		[%]	100			
Nominal voltage		[V]	12			
Max. current		[A]	2.3			
Coil resistance		[Ohm]	4 at 20°C			
Solenoid connection			Connector as per EN175301-803			
Protection class			IP65 in accordance with EN 60529 (plugged and mounted)			
Power amplifier			PCD00A-400			

Signal/pressure curve R5V*P2

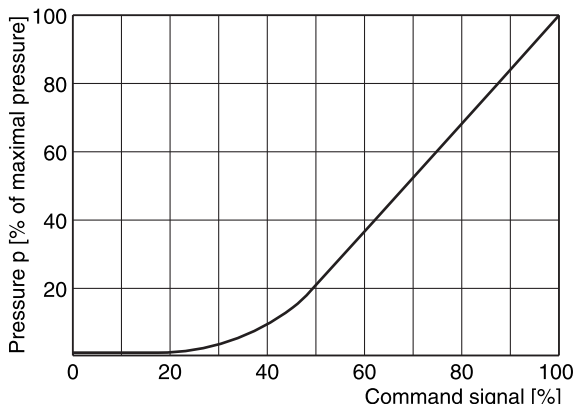

**p/Q performance curve ¹⁾
 R5V06*P2**

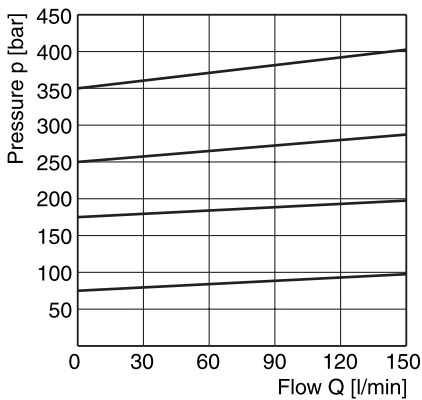

R5V08*P2

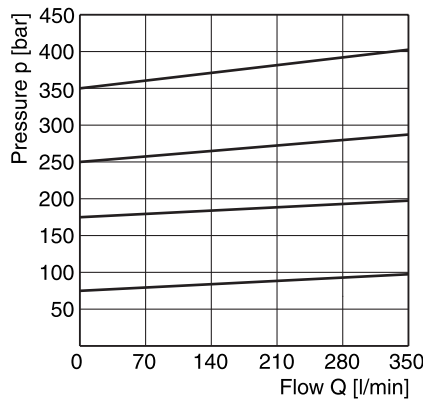

R5V10*P2

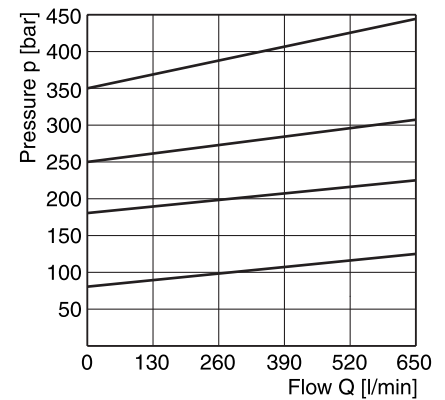

9

**Minimum pressure curve ¹⁾
 R5V06*P2**

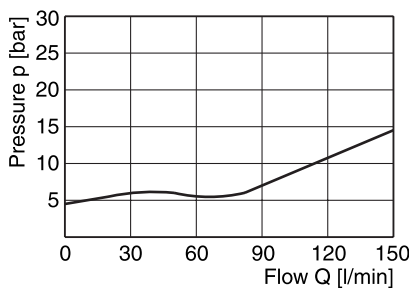

R5V08*P2

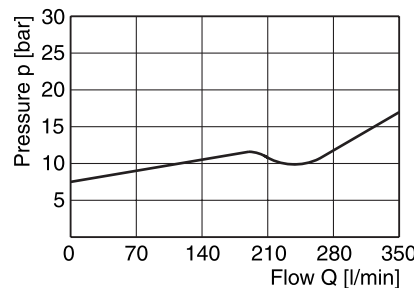

R5V10*P2

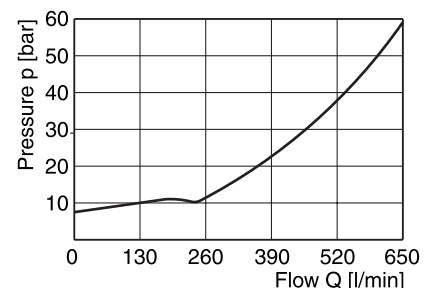

¹⁾ The performance curves are measured with external drain.
 For internal drain the tank pressure has to be added to curve.

Dimensions

**Pilot Operated Pressure Relief Valve
Series R5V*P2 (Denison)**

R5V*P2 2-port

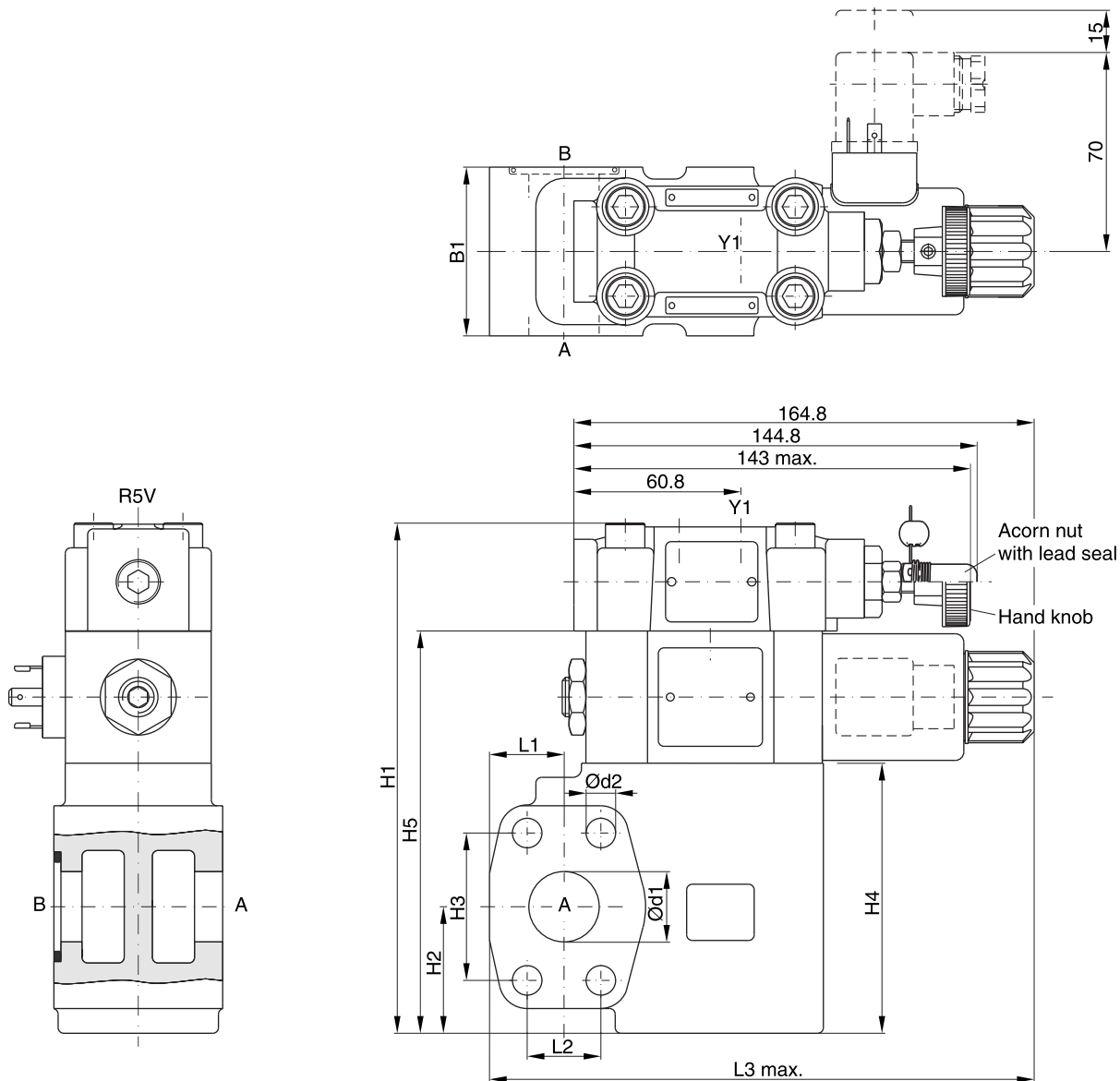

9

SAE61

NG	B1	H1	H2	H3	H4	H5	L1	L2	L3	d1	d2
06	60	175	37	47.6	90	137	24.6	22.2	174	19	10.5
08	60	181	45	52.4	96	143	26.5	26.2	193.6	25	10.5
10	75	194	48	58.7	109	156	34.0	30.2	201	32	12.5

Port	Function	Port size		
		R5V06	R5V08	R5V10
A	Pressure Tank	¾" SAE61	1" SAE61	1¼" SAE61
B		¾" SAE61	1" SAE61	1¼" SAE61
Y1	External drain	G¼"		

R5VP2_UK.INDD RH



Dimensions

**Pilot Operated Pressure Relief Valve
Series R5V*P2 (Denison)**

R5V*P2 3-port

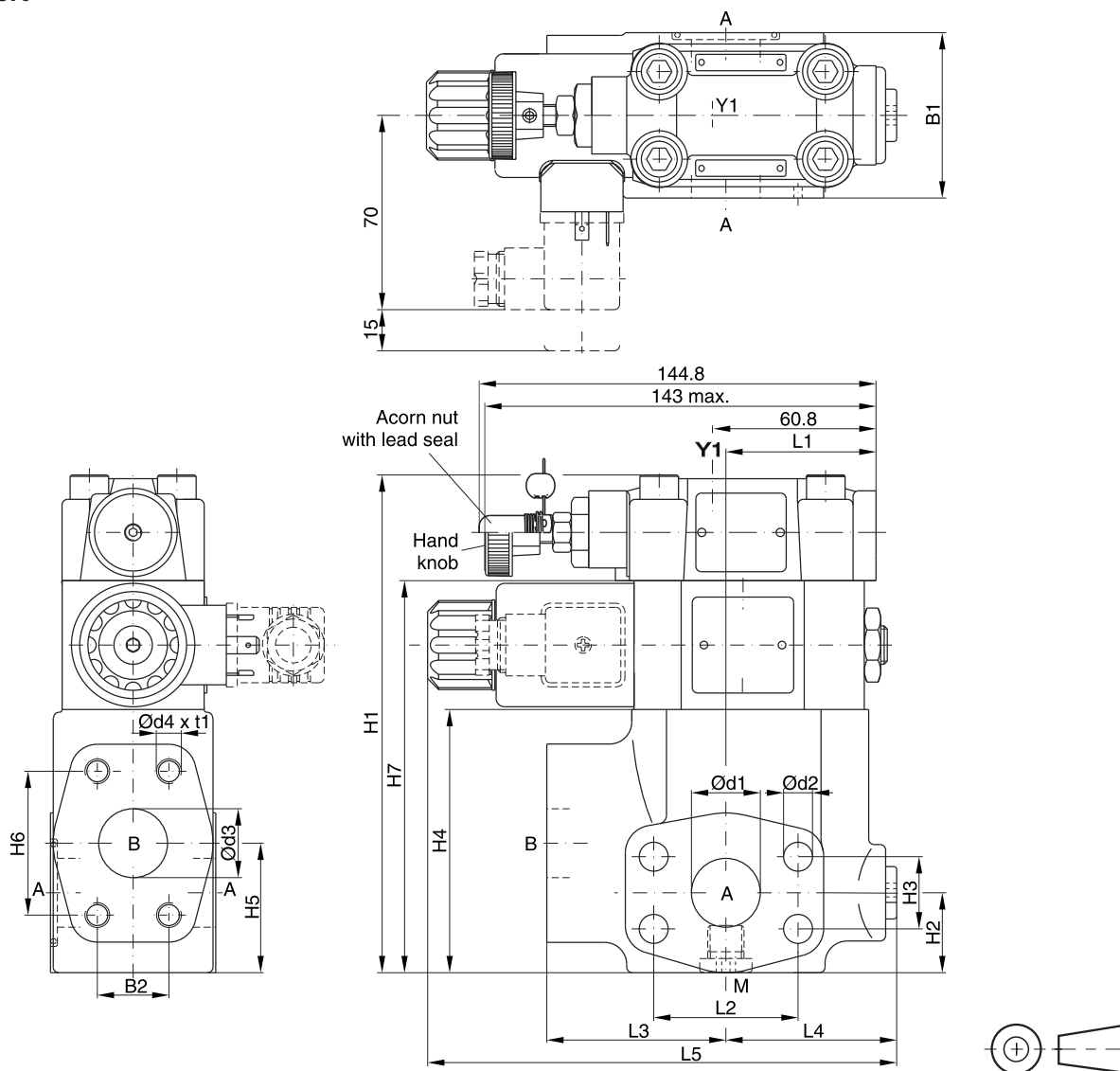

SAE61

NG	B1	B2	H1	H2	H3	H4	H5	H6	H7	L1	L2	L3	L4	L5	d1	d2	d3	d4 (option 152)	t1
06	60	22.2	166	28	22.2	81	41.6	47.6	128	50.3	47.6	63	56	174.6	19	10.5	19	3/8"-16 UNC (M10)	20
08	60	26.2	188	29	26.2	103	47	52.4	150	55.8	52.4	65	58	177	25	10.5	25	3/8"-16 UNC (M10)	23
10	75	30.2	198	34.5	30.2	113	64	58.7	160	57.8	58.7	61	62	179.1	32	12.5	32	7/16"-14 UNC (M12)	22
12	80	35.7	225	34	35.7	140	73	69.8	187	37.3	69.8	92.5	55.2	186.8	38	13.5	38	1/2"-13 UNC (M12)	27

SAE62

NG	B1	B2	H1	H2	H3	H4	H5	H6	L1	L2	L3	L4	L5	d1	d2	d3	d4 (option 152)	t1
06	60	23.8	119	28	23.8	81	41.6	50.8	50.3	50.8	63	56	152	19	10.5	19	3/8"-16 UNF (M10)	20
08	60	27.8	141	29	27.8	103	47	57.2	55.8	57.2	65	58	149	25	12.5	25	7/16"-14 UNC (M12)	22
10	75	31.8	151	34.5	31.8	113	64	66.7	57.8	66.7	61	62	150.5	32	13.5	32	1/2"-13 UNC (M12)	24
12	80	36.5	178	34	36.5	140	73	79.4	37.3	79.4	92.5	55.2	171.2	38	17	38	5/8"-11 UNC (M16)	33

Port	Function	Port size			
		R5V06	R5V08	R5V10	R5V12
A (2)	Pressure	3/4" SAE61	1" SAE61	1 1/4" SAE61	1 1/2" SAE61
B	Tank	3/4" SAE61	1" SAE61	1 1/4" SAE61	1 1/2" SAE61
Y1	External drain	G 1/4"			
M	Pressure gauge	G 1/4"			

R5VP2_UK.INDD RH



9

Characteristics / Ordering Code

**Pilot Operated Pressure Reducing Valve
Series R5R*P2 (Denison)**

Proportional pressure reducing valves series R5R*P2 are based on the mechanical adjusted series R5R. The additional proportional unit between the mechanical pilot valve and the main stage allows continuous pressure adjustment. The optimum performance can be achieved in combination with the digital amplifier module PCD00A-400.

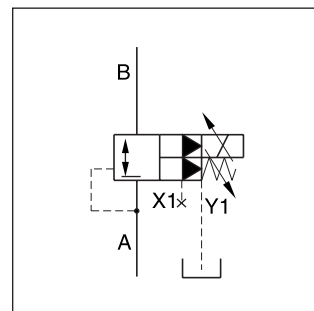

Features

- Pilot operated with proportional solenoid
- Continuous adjustment by proportional solenoid
- 2-port body with SAE61 flange
- 3 sizes (SAE 3/4", 1", 1 1/4")
- 3 pressure stages
- With mechanical maximum pressure adjustment

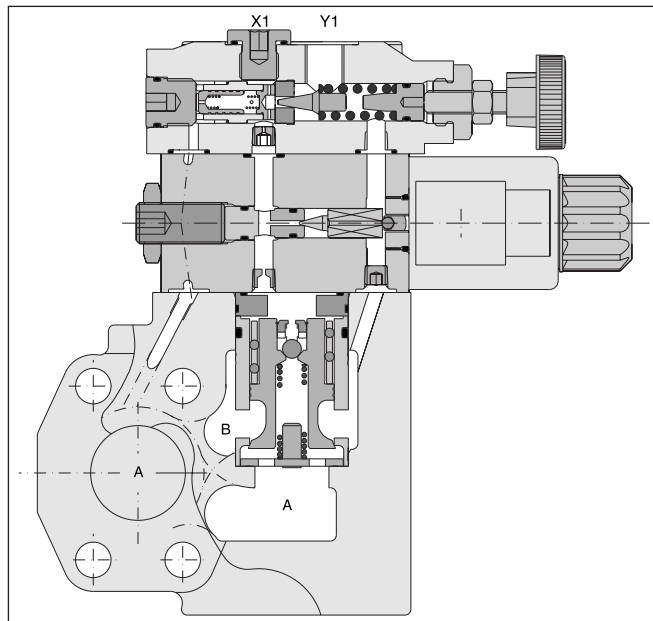

Ordering code

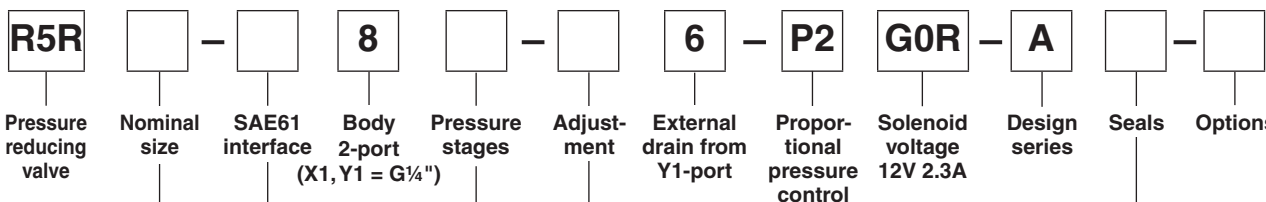

Code	Port size
06	SAE 3/4"
08	SAE 1"
10	SAE 1 1/4"

SAE 61		
Code	Size	Max. press. [bar]
4	10	280
5	06/08	350

Code	Pressure stages
1	up to 105bar
3	up to 210bar
5	up to 350bar

Code	Seals
1	NBR
5	FPM

Code	Adjustment
1	Hand knob
3	Acorn nut with lead seal

Further options on request

R5RP2_UK.INDD RH



Technical Data / Characteristic Curves

Technical data

General		06	08	10
Size				
Mounting		Flanged according to SAE 61		
Mounting position		unrestricted		
Ambient temperature	[°C]	-20...+50		
Weight	[kg]	5.8	6.4	7.7
Hydraulic				
Max. operating pressure	[bar]			
	Ports A, B, X1	350	350	280
	Port Y1	30	30	30
Pressure stages	[bar]	105, 210, 350		
Nominal flow	[l/min]	90	300	600
Fluid		Hydraulic oil as per DIN 51524...525		
Fluid temperature	[°C]	-20...+80		
Viscosity permitted	[cSt] [mm²/s]	10...650		
Viscosity recommended	[cSt] [mm²/s]	30		
Filtration		ISO 4406 (1999) 18/16/13 (acc. NAS 1638: 7)		
Electrical (proportional solenoid)				
Duty ratio	[%]	100		
Nominal voltage	[V]	12		
Max. current	[A]	2.3		
Coil resistance	[Ohm]	4 at 20°C		
Solenoid connection		Connector as per EN175301-803		
Protection class		IP65 in accordance with EN 60529 (plugged and mounted)		
Power amplifier		PCD00A-400		

Command / pressure curve

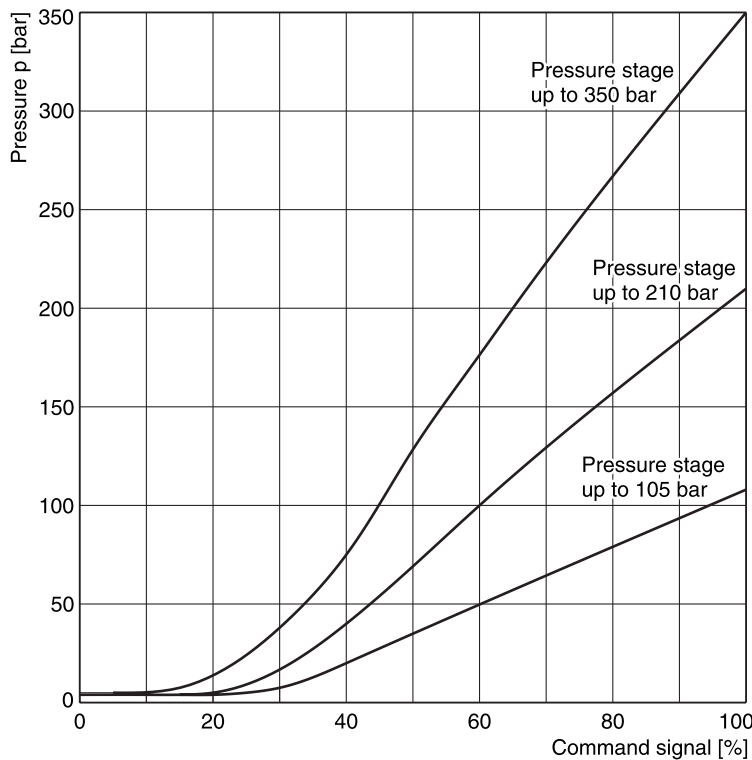

**Reduced pressure pA vs. flow Q
Series R5R06*P2 ¹⁾**

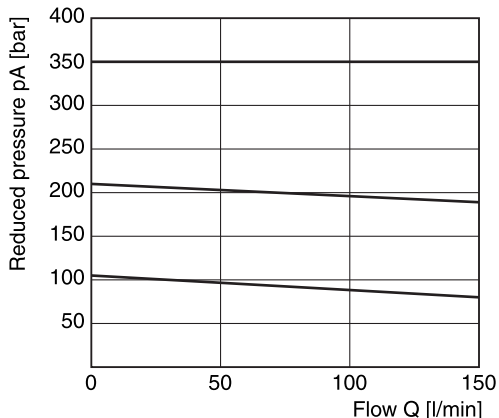

Minimum pressure curve

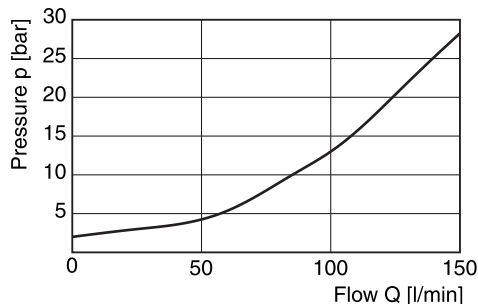

**Reduced pressure pA vs. flow Q
Series R5R08*P2 ¹⁾**

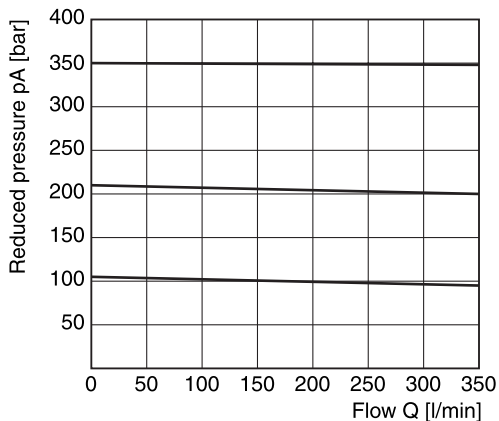

Minimum pressure curve

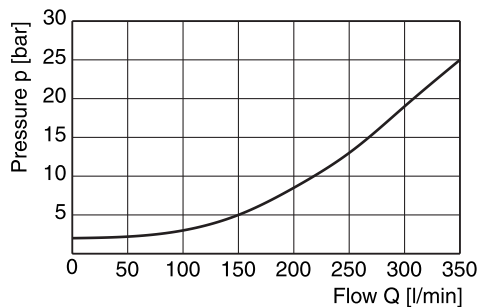

**Reduced pressure pA vs. flow Q
Series R5R10*P2 ¹⁾**

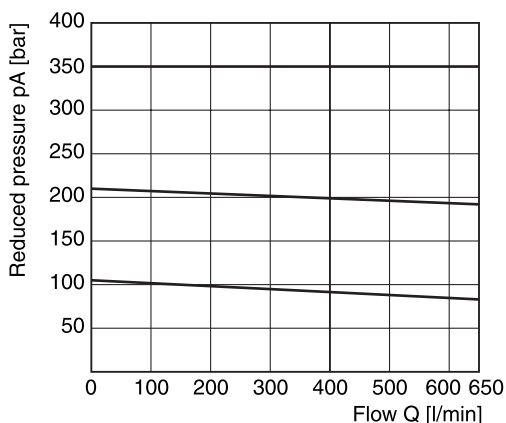

Minimum pressure curve

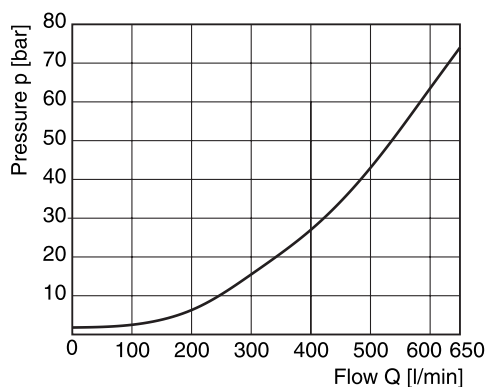

¹⁾ Measured at 350 bar primary pressure pB.

Dimensions

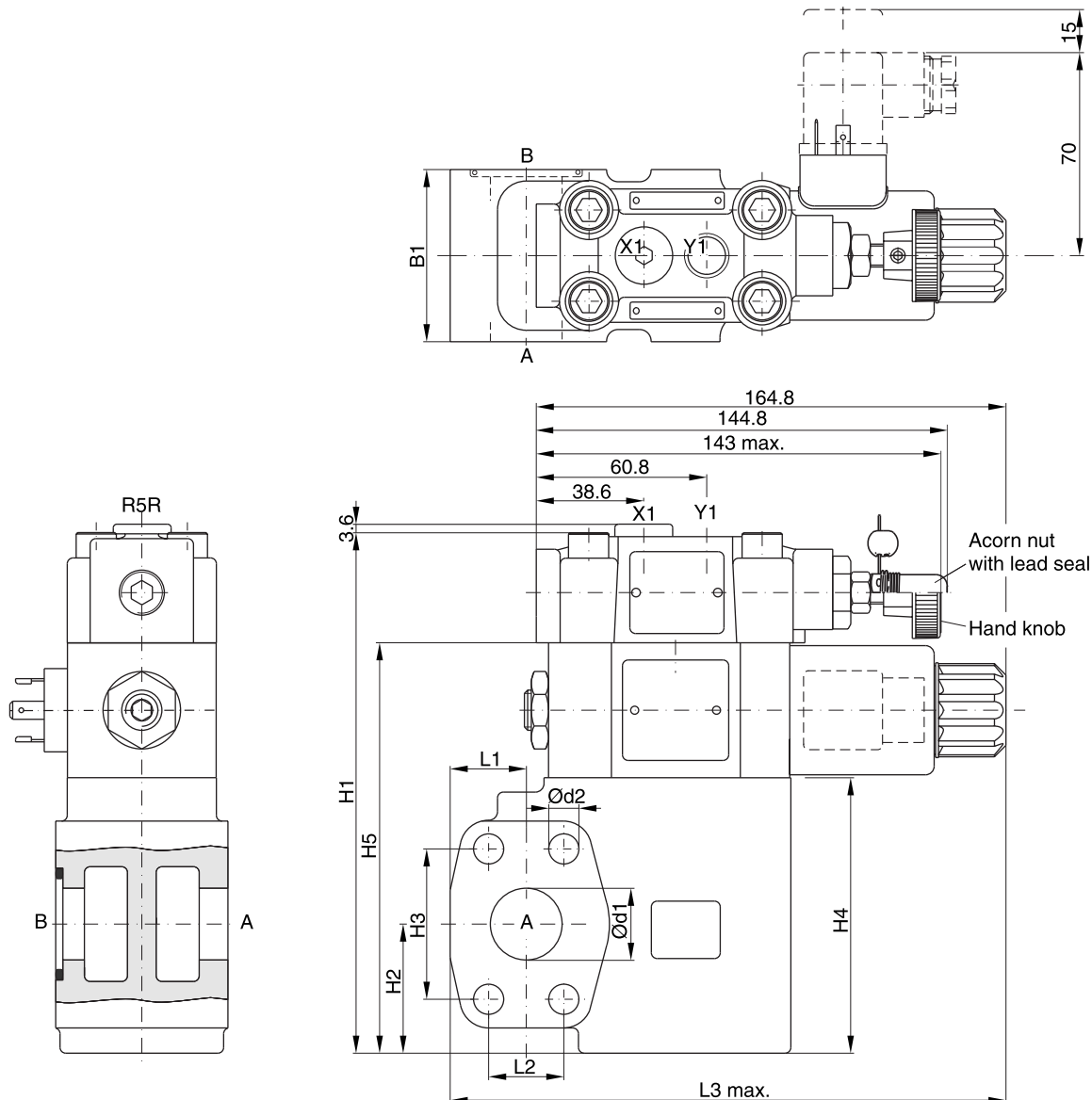

NG	B1	H1	H2	H3	H4	H5	L1	L2	L3	d1	d2
06	60	175	37	47.6	90	137	24.6	22.2	174	19	10.5
08	60	181	45	52.4	96	143	26.5	26.2	193.6	25	10.5
10	75	194	48	58.7	109	156	34.0	30.2	201	32	12.5

Port	Function	Port size		
		R5R06	R5R08	R5R10
B	Inlet pressure	3/4" SAE61	1" SAE61	1 1/4" SAE61
A	Reduced outlet pressure	3/4" SAE61	1" SAE61	1 1/4" SAE61
Y1	External drain	G 1/4"		
X1	Pressure gauge	G 1/4"		

R5RP2_UK.INDD RH



9

Characteristics

Seat valves series D5S are designed for directional control functions. They enable individual hydraulic solutions for nominal flow up to 800 l/min due to a large variety of poppets, springs and covers, including shuttle valves, stroke limiters, solenoid valves (VV01) and position control.

A complete program is offered under the Denison brand: subplate mounted valves (D4S - chapter 6), SAE flange valves (D5S - chapter 9), pipe mounted valves (D4S - chapter 10), slip-in cartridges (CAR - on request).

Features

- Leak-free seat valve design
- 2- and 3-port bodies
- SAE61 flange
- Numerous pilot options
- 6 poppet types
- 4 sizes, SAE 3/4", 1", 1 1/4", 1 1/2"

**Directional Seat Valve
Series D5S (Denison)**



D5S 2-port



D5S 3-port

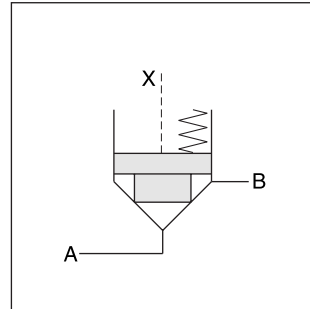

D5S 2-port

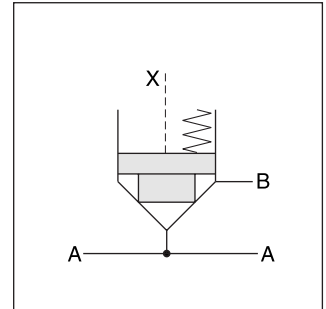

D5S 3-port

D5S 2-port

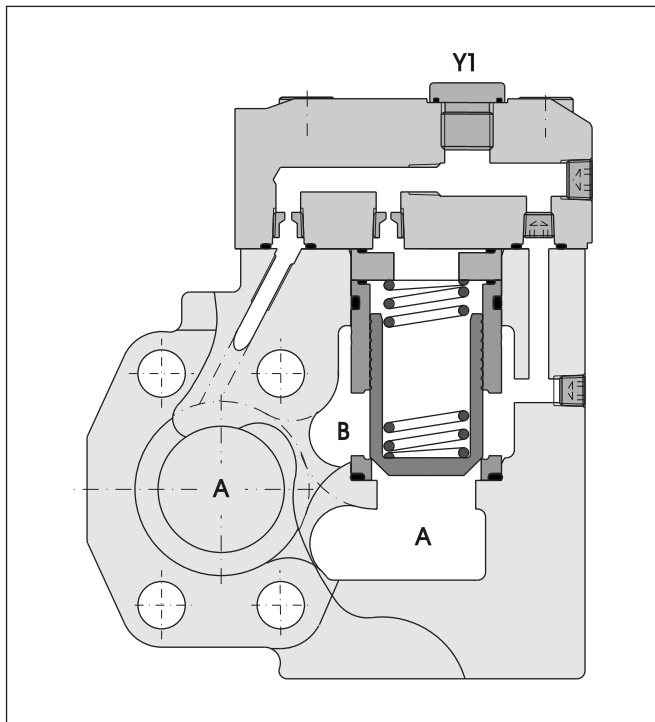

D5S 3-port

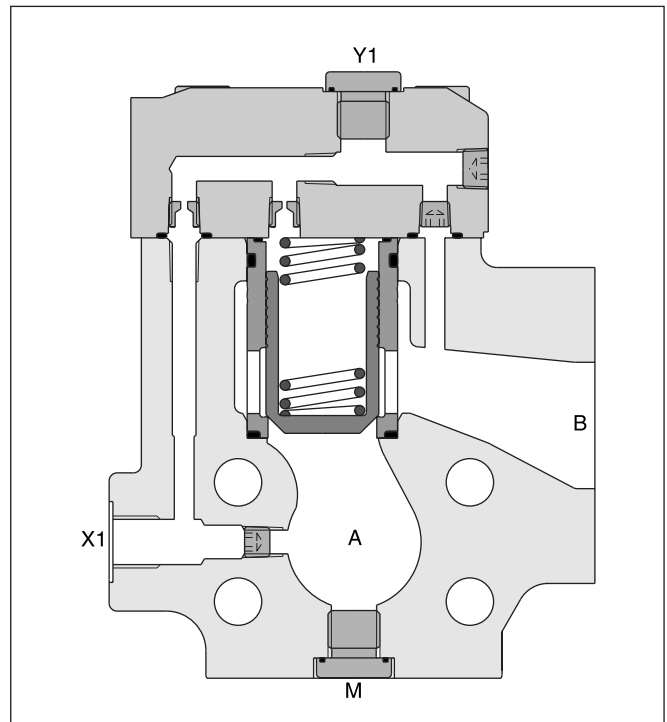

Directional Seat Valve Series D5S (Denison)

Ordering Code

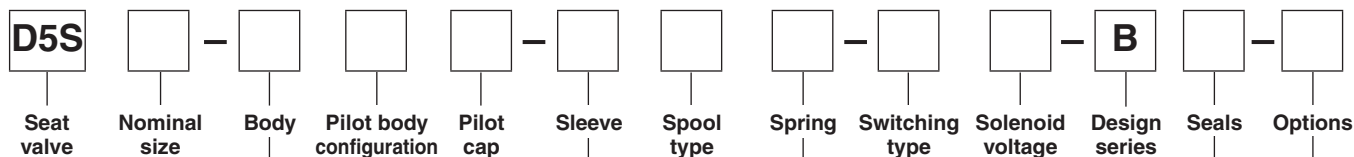

Code	Port size
06	SAE 3/4"
08	SAE 1"
10	SAE 1 1/4"
12 ¹⁾	SAE 1 1/2"

¹⁾ D5S 3-port only

Code	Body	Ports
5	3-port	Seat entry, A; X1, Y1, M = G 1/4"
7	2-port	Seat entry, A; X1, Y1 = G 1/4"
8	2-port	Annular entry, B; X1, Y1 = G 1/4"

Code	Pilot oil line in body
1	internal from A
2	internal from B
3	internal from A and B
4	external from X1
5	int. from B, ext. from X1

Code	Body	Ports	X	Y	Z	X-Y	X1	Y1	VV01
Standard									
1	2-/3-port	Pilot oil = pilot drain	●	●	○	○	○	○	○
2	2-/3-port	Pilot oil = pilot drain	●	○	○	○	○	○	○
3	2-port	Pilot oil = pilot drain	●	○	○	○	○	○	○
With solenoid valve (VV01)									
4	2-/3-port	Internal to B	○	○	○	○	○	○	○
5	2-port	Internal to B	○	○	○	○	○	○	○
6	2-/3-port	Ext. out of cap	○	○	○	○	○	○	○
7	2-port	Ext. out of cap	○	○	○	○	○	○	○
With stroke limiter (not for D5S06)									
A	2-/3-port	Pilot oil = pilot drain	○	○	○	○	○	○	○
B	2-/3-port	Pilot oil = pilot drain	○	○	○	○	○	○	○
C	2-port	Pilot oil = pilot drain	○	○	○	○	○	○	○

○ open bore ● closed bore ◐ orifice Ø 1.2

Note: Combination examples at the end of chapter

Code	Sleeve
1	AA=95%, AB=5%
3	AA=60%, AB=40%

Code	Size	Poppet type	Sleeve
1	06, 08, 10, 12	With closed bottom and 15° chamfer (pZ max. = pA +20bar)	1
2	06	With 0.8 dia. orifice at the bottom and 15° chamfer	1
	08, 10	With 1.2 dia. orifice at the bottom and 15° chamfer	1
4	06, 08, 10, 12	With closed bottom and 45° chamfer	1, 3
A ²⁾	08, 10, 12	Safety spool (for end position control only)	3
B ²⁾	08, 10, 12	Throttle spool, 10° chamfer	3
C ²⁾	08, 10, 12	Throttle spool, 3° chamfer	3

²⁾ Springs 2, 3, 4 and 6 only

Code	Options
omit	Standard
013	Position control with protection

Code	Seals
1	NBR
5	FPM

Code	Solenoid voltage
omit	Standard
G0R	12V=
G0Q	24V=
GAR	98V=
GAG	205V=
W06	115V / 50Hz
W07	230V / 50Hz

Code	Switching type
omit	Standard
09	VV01 with manual override
10	VV01 without manual override
11	VV01 with manual override
12	VV01 without manual override
CA	Shuttle valve
DA	Shuttle valve
CB	VV01 code 09 and shuttle valve code CA
CD	VV01 code 11 and shuttle valve code CA
DB	VV01 code 09 and shuttle valve code DA
DD	VV01 code 11 and shuttle valve code DA
BH	VV01 code 10 and shuttle valve code CA and position control ³⁾ with amplifier
BK	VV01 code 12 and shuttle valve code CA and position control ³⁾ with amplifier
BN	VV01 code 10 and shuttle valve code DA and position control ³⁾ with amplifier
BQ	VV01 code 12 and shuttle valve code DA and position control ³⁾ with amplifier
BC	VV01 code 10 and position control ³⁾ with amplifier
BE	VV01 code 12 and position control ³⁾ with amplifier
BA	Position control ³⁾ with amplifier
BF	Position control ³⁾ with amplifier and shuttle valve code CA
BL	Position control ³⁾ with amplifier and shuttle valve code DA

³⁾ Position control for D5S08/10 only. Spring 2 or 4. Spool A and sleeve 3.

Code	Spring (approx. cracking pressure [bar])					
	Sleeve Code 1		Sleeve Code 3			
	A -> B		A -> B		B -> A	
	D5S06	D5S08/12	D5S06	D5S08/12	D5S06	D5S08/12
1	2.8	3.5	6.5	6.5	9.5	11.0
2	0.5	0.5	1.0	1.0	1.5	1.7
3	0.3	0.3	0.6	0.6	0.9	1.0
4	2.2	2.2	4.0	3.5	5.5	6.0
5	—	9.0	—	16.0	—	28.0
6	1.2	1.2	2.0	2.2	3.0	3.8
7	3.0	—	8.0	—	12.0	—

Technical data

General		06	08	10	12		
Size							
Mounting		Flanged according to SAE 61					
Mounting position		unrestricted					
Ambient temperature	[°C]	-20...+50					
Weight	D5S 2port [kg]	3.6	4.1	5.4	—		
	D5S 3port [kg]	3.4	4.4	5.0	7.8		
Hydraulic							
Max. operating pressure	[bar]						
	SAE61 Ports A, B	350	350	280	210		
	Port Y1	30	30	30	30		
Nominal flow	[l/min]	180	360	600	800		
Fluid		Hydraulic oil as per DIN 51524...525					
Fluid temperature	[°C]	-20...+80					
Viscosity permitted	[cSt]/[mm²/s]	10...650					
Viscosity recommended	[cSt]/[mm²/s]	30					
Filtration		ISO 4406 (1999) 18/16/13 (acc. NAS 1638: 7)					
Electrical (solenoid)							
Duty ratio	[%]	100					
Response time	[ms]	Energized / De-energized AC: 20/18 , DC: 46/27					
Supply voltage		G0R	G0Q	GAR	GAG	W06	W07
Tolerance supply voltage		12V = +5...-10	24V = +5...-10	98V = +5...-10	205V = +5...-10	150 at 50Hz	230 at 50Hz
Power consumption	hold	31	31	31	31	78	78
	in rush	31	31	31	31	264	264
Max. switching frequency		AC: up to 7200, DC: up to 16000 switchings/hour					
Solenoid connection		Connector as per EN175301-803					
Protection class		IP65 in accordance with EN 60529 (plugged and mounted)					
Coil insulation class		H (180 °C)					

D5S pilot configuration

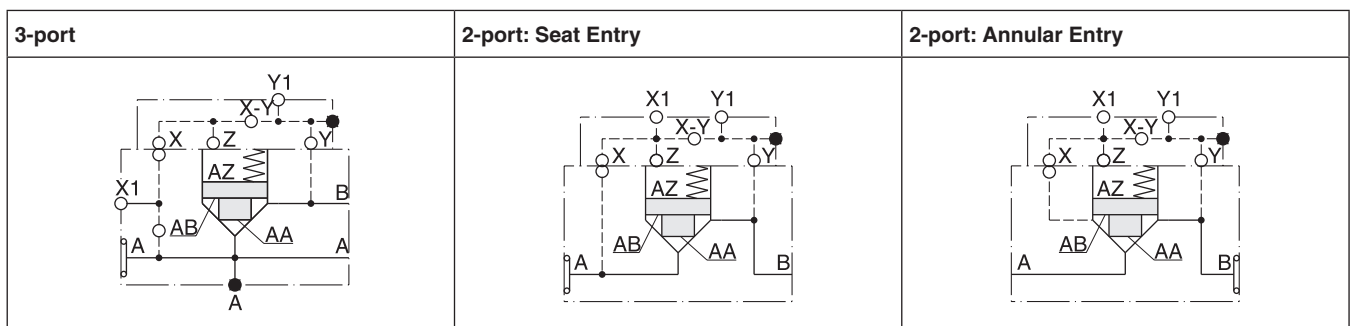

D5S 2-port

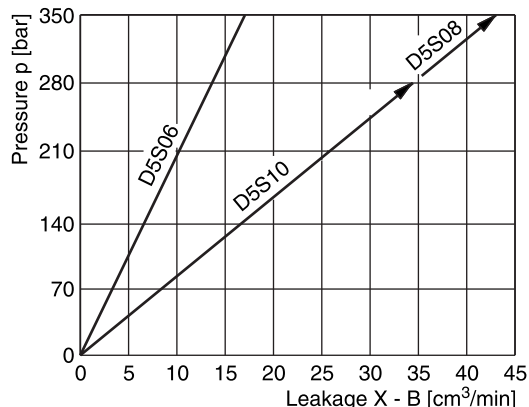
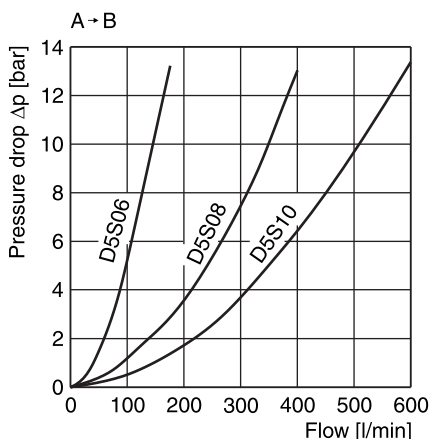

D5S 3-port

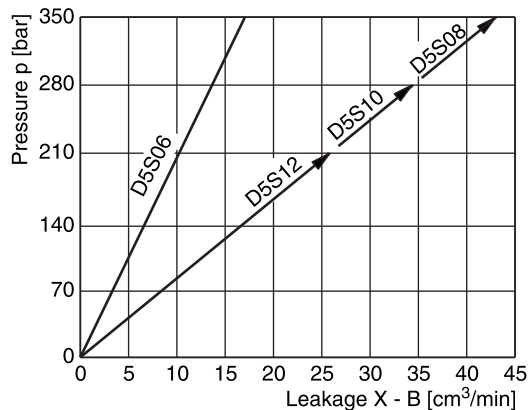
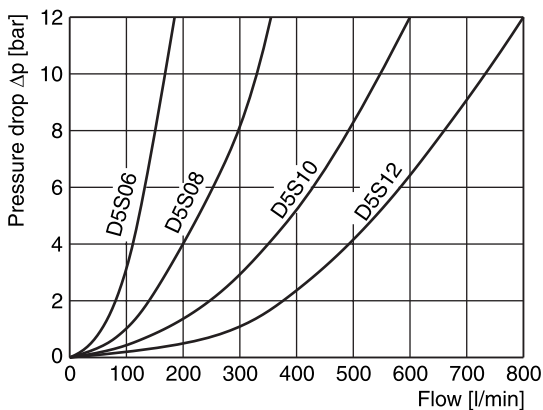

Fluid viscosity 38cSt at 50 °C

Selection of Cartridges

Sleeve 1, poppet 1	Sleeve 1, poppet 2	Sleeve 1, poppet 4	Sleeve 3, poppet 4	Sleeve 3, poppet A	Sleeve 3, poppet B/C
1 : 1.05 $A_A = 0.95 A_C$ $A_B = 0.05 A_C$ 15° chamfer	1 : 1.05 $A_A = 0.95 A_C$ $A_B = 0.05 A_C$ 15° chamfer orifice	1 : 1.05 $A_A = 0.95 A_C$ $A_B = 0.05 A_C$ 45° chamfer	1 : 1.67 $A_A = 0.6 A_C$ $A_B = 0.4 A_C$ 45° chamfer	1 : 1.67 $A_A = 0.6 A_C$ $A_B = 0.4 A_C$ 45° chamfer safety spool	1 : 1.67 $A_A = 0.6 A_C$ $A_B = 0.4 A_C$ 45° chamfer throttle spool

D5S_UK.INDD RH

Example pilot oil external from X1, pilot drain internal out of B

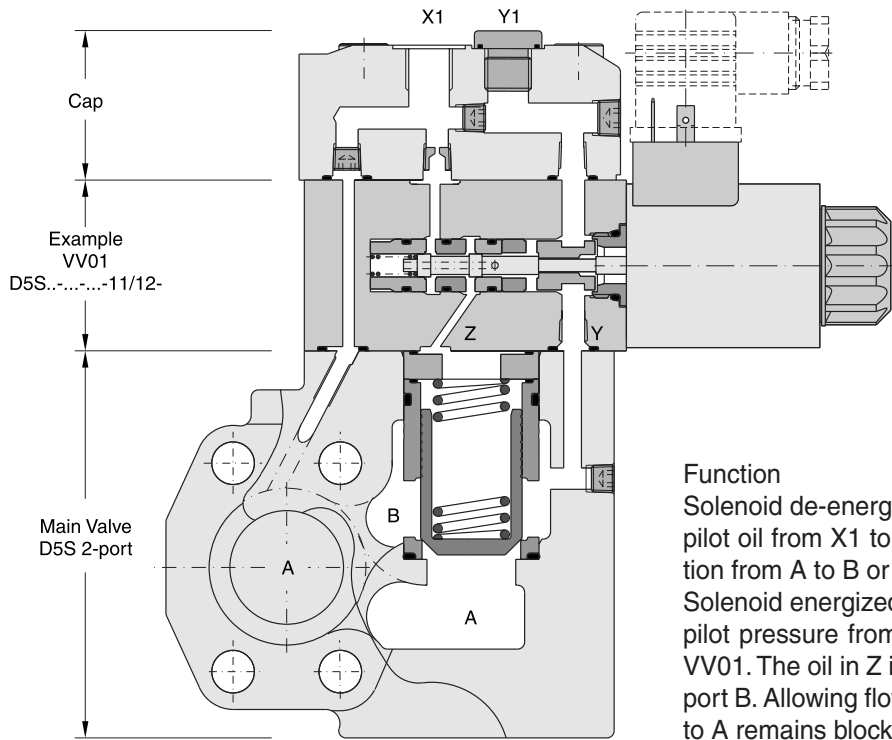

Function
 Solenoid de-energized:
 pilot oil from X1 to Z blocks the connection from A to B or B to A.
 Solenoid energized:
 pilot pressure from X1 is blocked in the VV01. The oil in Z is internally drained to port B. Allowing flow from A to B, while B to A remains blocked.

D5S with VV01 dimensions

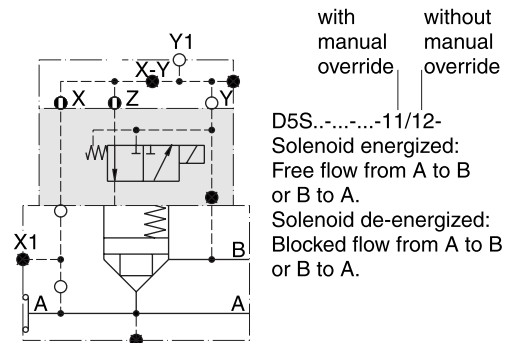
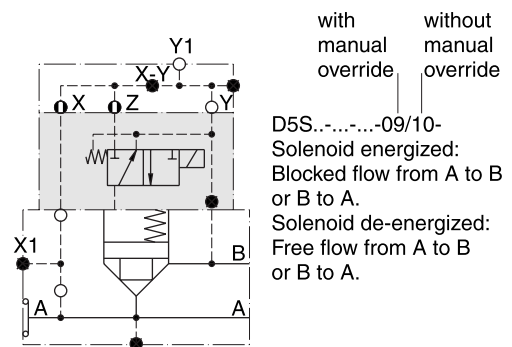
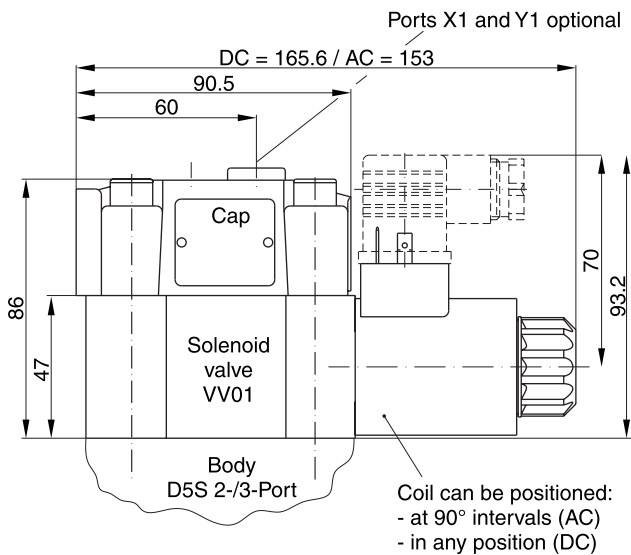

D5S with position control

Position control by proximity switch (incl. amplifier). Valve open: proximity switch activated. This proximity switch is pressure proof and has no wearing parts.

Note: Position control for D5S08 and D5S10 only.

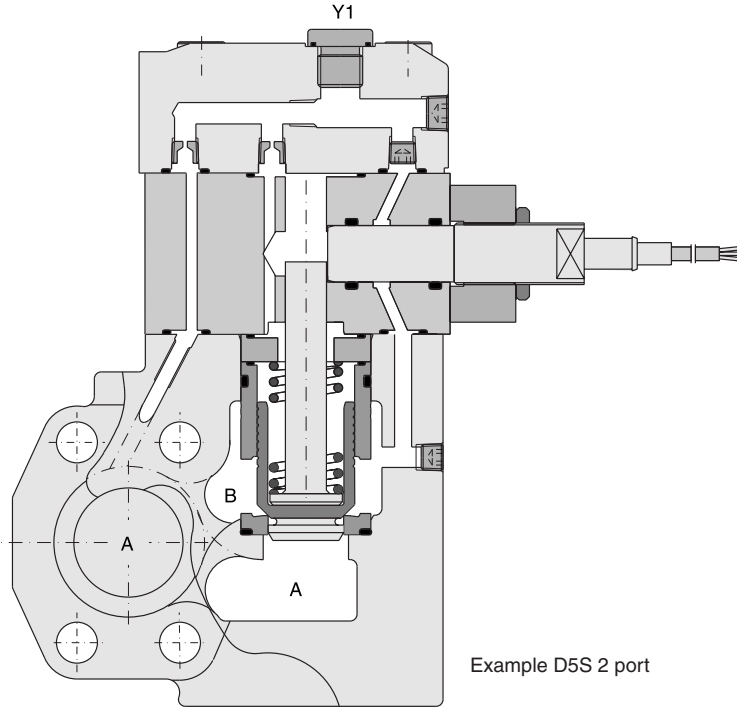

Example D5S 2 port

D5S with position control dimensions

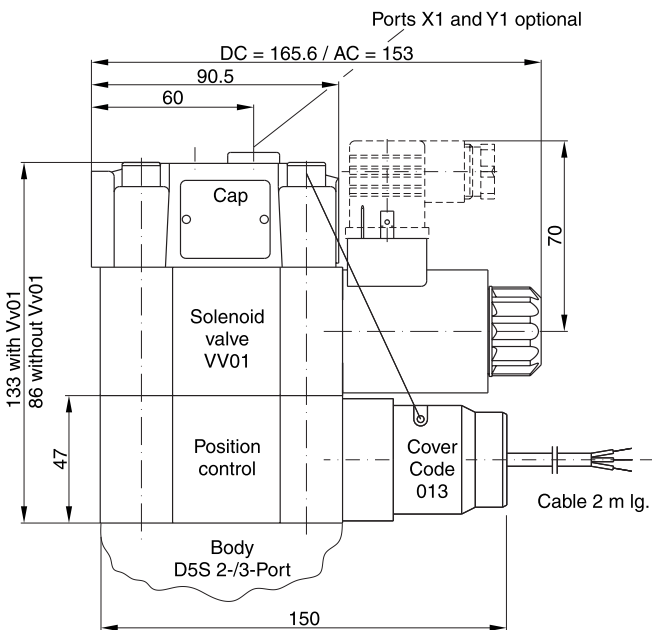

Technical data (proximity switch)

Function		PNP, contact
Supply voltage (Us)	[VDC]	10...30
Supply voltage ripple	[%]	≤ 10
Current consumption	[mA]	max. 8
Residual voltage L-signal	[V]	Us - 2.2 at I _{max}
Output current (I)	[mA]	≤ 200
Protection class		IP67
Ambient temperature	[C°]	-25...+70
Wire cross section	[mm ²]	3 x 0.5

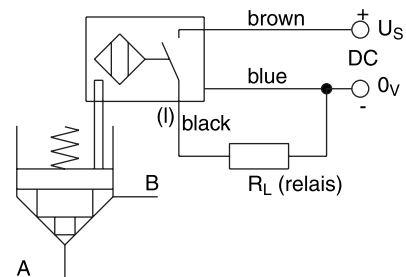
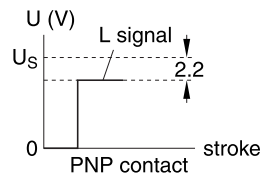

9

D5S stroke limiter

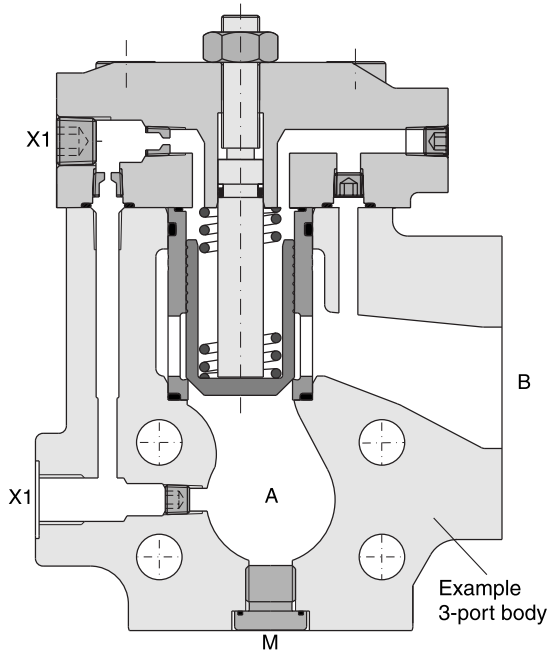

X1 = external pilot-oil (optional)
 Note: Stroke limiter not for use with D5S06, solenoid valve VV01, shuttle valve and position control.

Stroke limiter dimensions

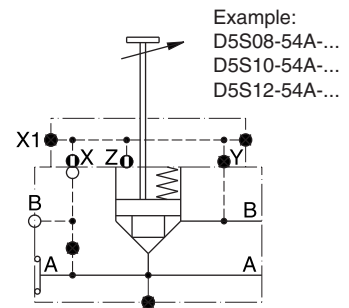
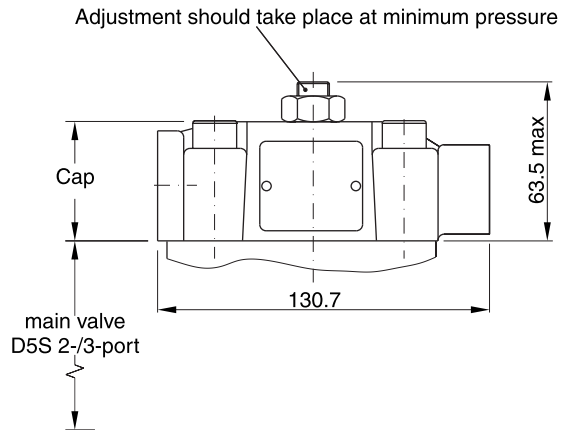

D5S with shuttle valve

Dimensions

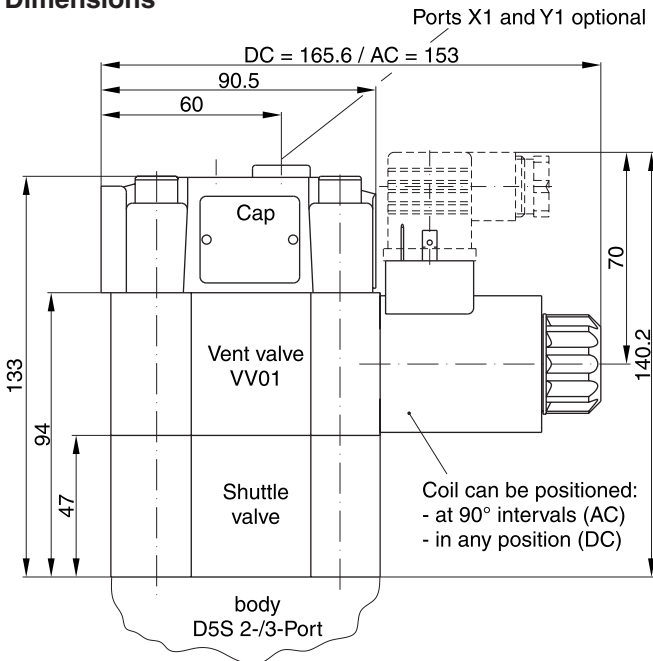

Shuttle valve only in connection with vent valve VV01.

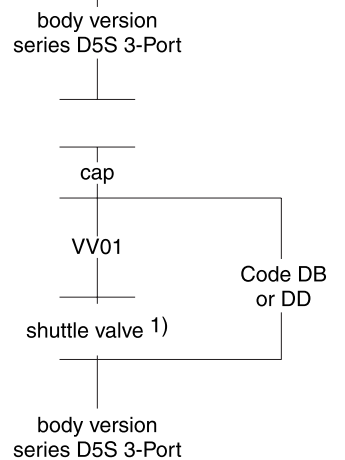
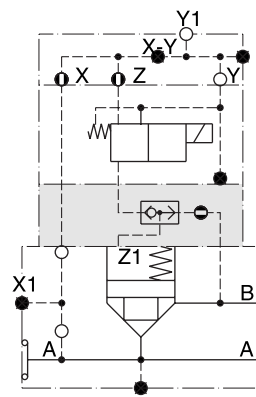
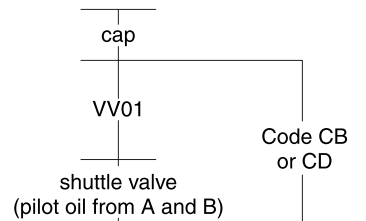
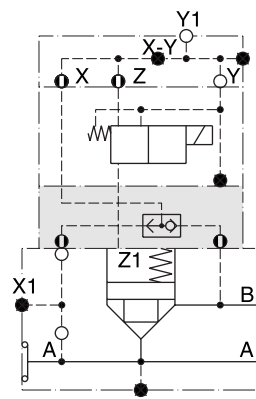

1) pilot oil from A and B, from B to A check valve function

D5S 2-port

Seat entry

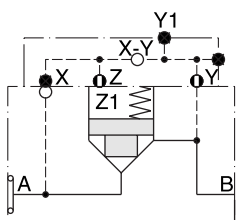

D5S...-122-

7

Pilot oil: internal from B

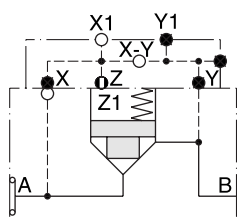

D5S...-143-

7

Pilot oil: external from X1

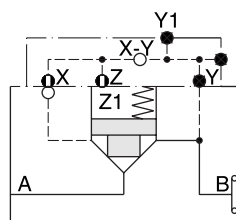

D5S...-221-

8

Pilot oil: internal from B

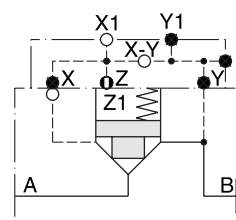

D5S...-243-

8

Pilot oil: external from X1

Stroke limiter D5S 2-port

Seat entry

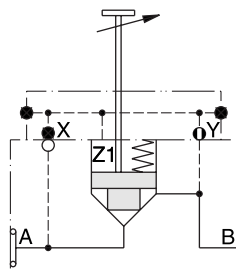

D5S08-12B-

10 7

Pilot oil: internal from B

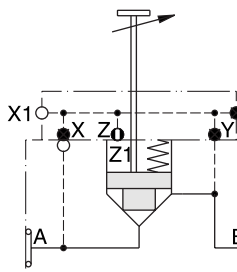

D5S08-14C-

10 7

Pilot oil: external from X1

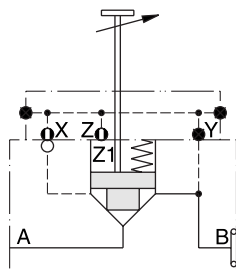

D5S08-22A-

10 8

Pilot oil: internal from B

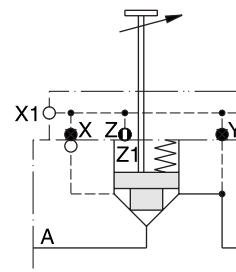

D5S08-24C-

10 8

Pilot oil: external from X1

D5S 3-port

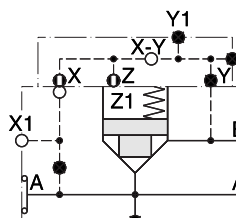

D5S...-541-

9

Pilot oil: external from X1

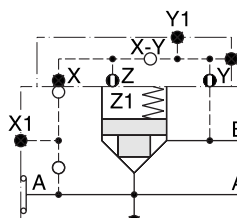

D5S...-522-

9

Pilot oil: internal from B

Stroke limiter D5S 3-port

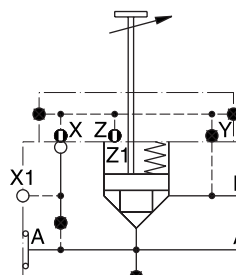

D5S 08 -54A-

10 9

12

Pilot oil: external from X1

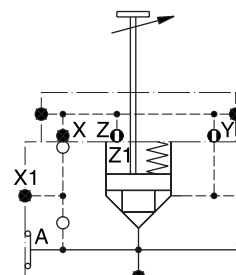

D5S 08 -52B-

10 9

12

Pilot oil: internal from B

9

D5S 2-port with solenoid valve VV01

Seat entry

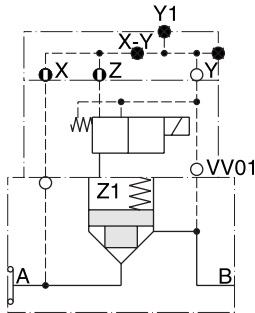

D5S .. -114-09-
7 10
11
12

Pilot oil: internal from A
Pilot drain: internal to B

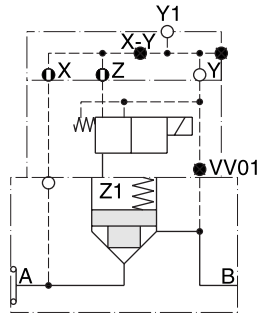

D5S .. -116-09-
7 10
11
12

Pilot oil: internal from A
Pilot drain: external out of Y1

Annular entry

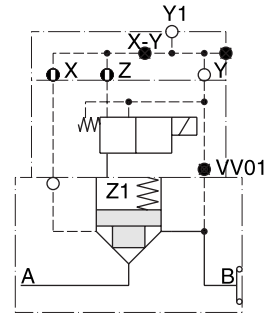

D5S .. -226-09-
8 10
11
12

Pilot oil: internal from B
Pilot drain: external out of Y1

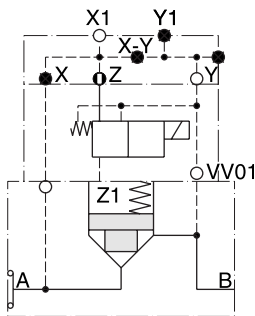

D5S .. -145-09-
7 10
11
12

Pilot oil: internal from X1
Pilot drain: internal to B

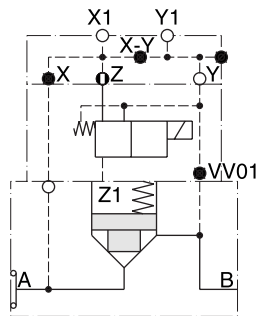

D5S .. -147-09-
7 10
11
12

Pilot oil: internal from X1
Pilot drain: external out of Y1

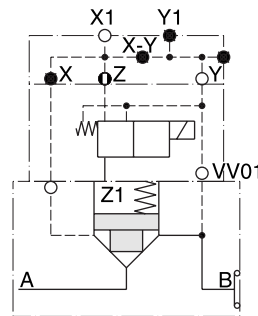

D5S .. -245-09-
8 10
11
12

Pilot oil: internal from X1
Pilot drain: internal to B

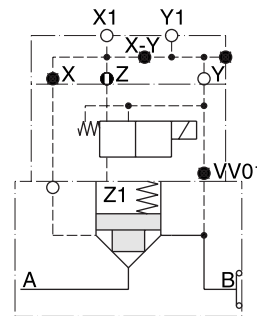

D5S .. -247-09-
8 10
11
12

Pilot oil: internal from X1
Pilot drain: external out of Y1

D5S 2-port with with solenoid valve VV01 and shuttle valve

Seat entry

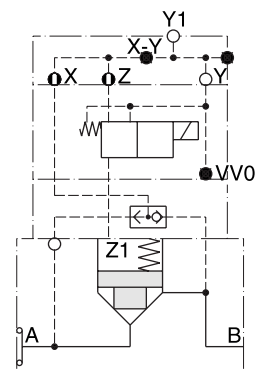

D5S .. -136-...-CB-
7 CD

Pilot oil: internal from A +
internal from B
Pilot drain: external out of Y1

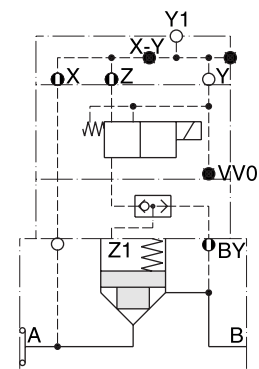

D5S .. -136-...-DB-
7 DD

Pilot oil: internal from A +
internal from B
Pilot drain: external out of Y1

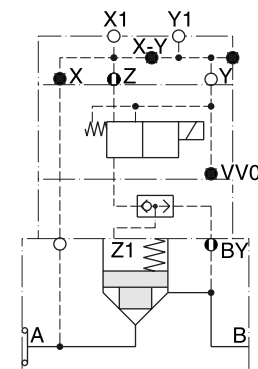

D5S .. -157-...-DB-
7 DD

Pilot oil: external from X1 +
internal from B
Pilot drain: external out of Y1

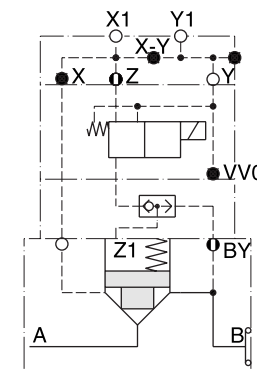

D5S .. -857-...-DB-
2 DD

Pilot oil: external from X1 +
internal from B
Pilot drain: external out of Y1

D5S 3-port with solenoid valve VV01

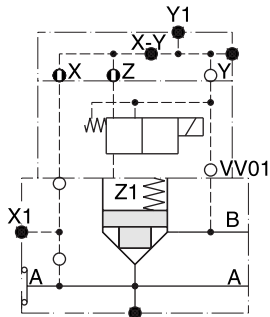

D5S .. -514-09-
9 10
11
12

Pilot oil: internal from A
Pilot drain: internal to B

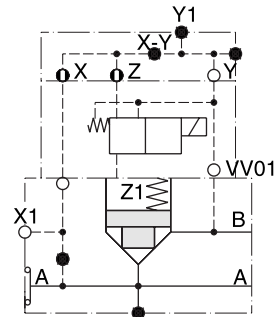

D5S .. -544-09-
9 10
11
12

Pilot oil: external from X1
Pilot drain: internal to B

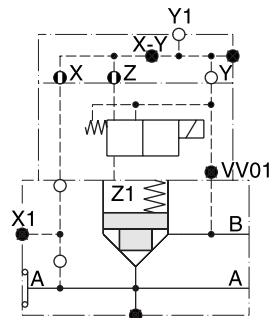

D5S .. -516-09-
9 10
11
12

Pilot oil: internal from A
Pilot drain: external out of Y1

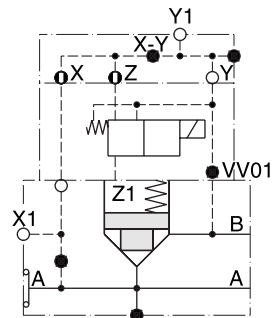

D5S .. -546-09-
9 10
11
12

Pilot oil: external from X1
Pilot drain: external out of Y1

9

D5S 3-port with with solenoid valve VV01 and shuttle valve

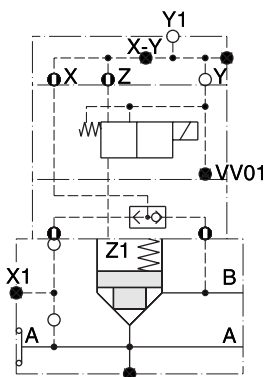

D5S .. -536-...-CB-
9 CD

Pilot oil: internal from A +
internal from B
Pilot drain: external out of Y1

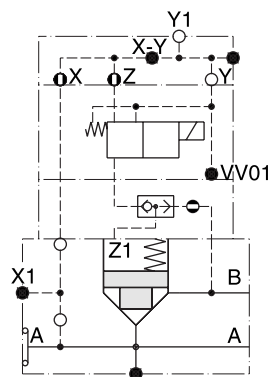

D5S .. -536-...-DB-
9 DD

Pilot oil: internal from A +
internal from B
Pilot drain: external out of Y1

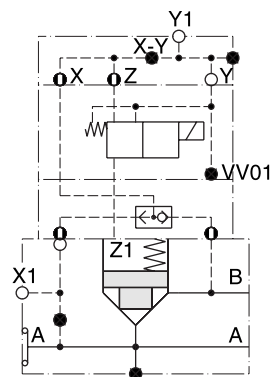

D5S .. -556-...-CB-
9 CD

Pilot oil: internal from X1 +
internal from B
Pilot drain: external out of Y1

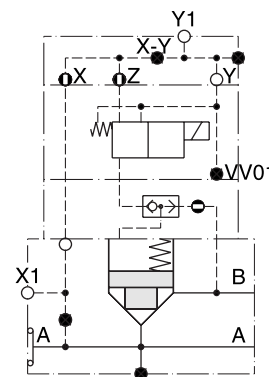

D5S .. -556-...-DB-
9 DD

Pilot oil: external from X1 +
internal from B
Pilot drain: external out of Y1

D5S 2-port position control

Seat entry

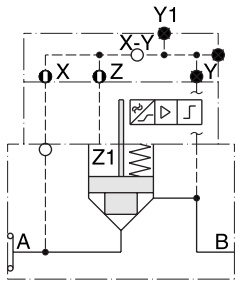

D5S 08 -111-3A.-BA-
D5S 10 7

Pilot oil: internal from A

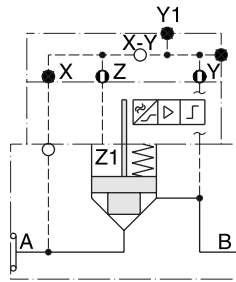

D5S 08 -122-3A.-BA-
D5S 10 7

Pilot oil: internal from B

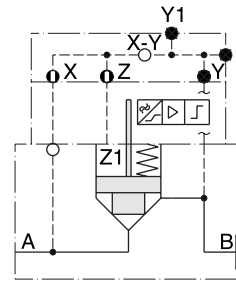

D5S 08 -221-3A.-BA-
D5S 10 8

Pilot oil: internal from B

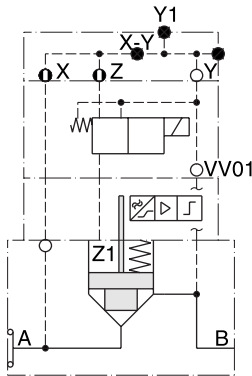

D5S 08 -114-3A.-BC-
D5S 10 7 BE

Pilot oil: internal from A
Pilot drain: internal to B

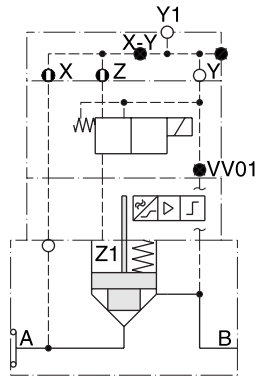

D5S 08 -116-3A.-BC-
D5S 10 7 BE

Pilot oil: internal from A
Pilot drain: external out of Y1

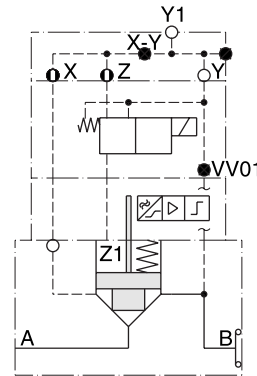

D5S 08 -226-3A.-BC-
D5S 10 8 BE

Pilot oil: internal from B
Pilot drain: external out of Y1

Seat entry

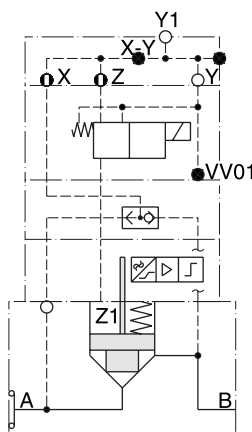

D5S ...-136...-BH-
7 BK

Pilot oil: internal from A +
internal from B
Pilot drain: external out of Y1

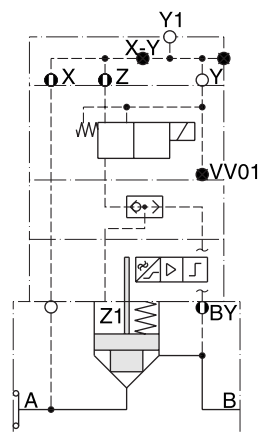

D5S ...-136...-BN-
7 BQ

Pilot oil: internal from A +
internal from B
Pilot drain: external out of Y1

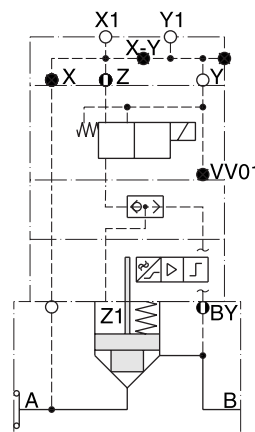

D5S ...-157...-BN-
7 BQ

Pilot oil: external from X1 +
internal from B
Pilot drain: external out of Y1

Annular entry

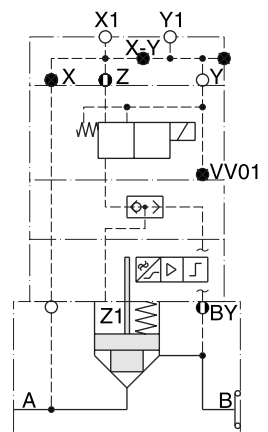

D5S ...-857...-BN-
2 BQ

Pilot oil: external from X1 +
internal from B
Pilot drain: external out of Y1

D5S 3-port position control

Seat entry

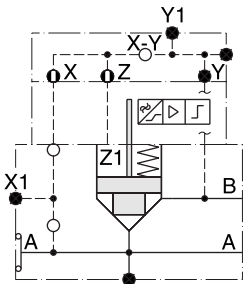

D5S 08 -511-3A.-BA-
10 9
12

Pilot oil: internal from A

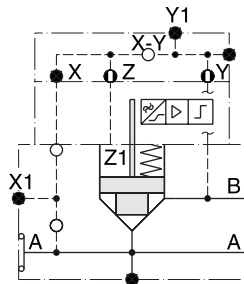

D5S 08 -522-3A.-BA-
10 9
12

Pilot oil: internal from B

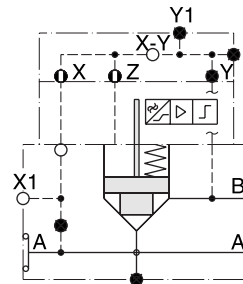

D5S 08 -521-3A.-BA-
10 9
12

Pilot oil: external from X1

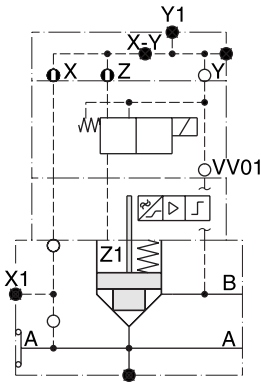

D5S 08 -514-3A.-BC-
10 9 BE
12

Pilot oil: internal from A
Pilot drain: internal to B

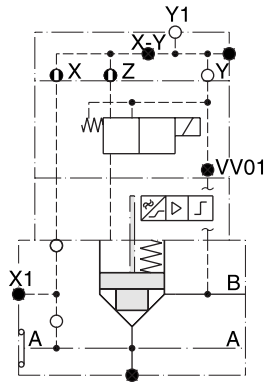

D5S 08 -516-3A.-BC
10 9 BE
12

Pilot oil: internal from A
Pilot drain: external out of Y1

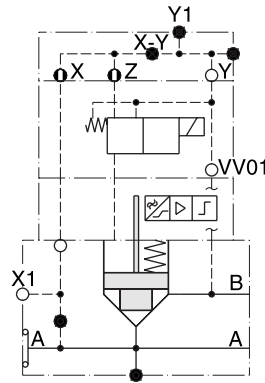

D5S 08 -544-3A.-BC-
10 9 BE
12

Pilot oil: external from X1
Pilot drain: internal to B

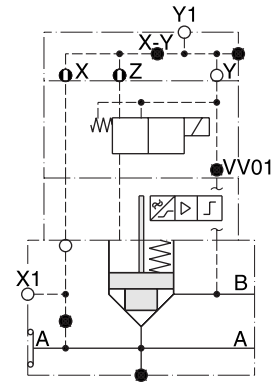

D5S 08 -546-3A.-BC-
10 9 BE
12

Pilot oil: external from X1
Pilot drain: external out of Y1

9

Seat entry

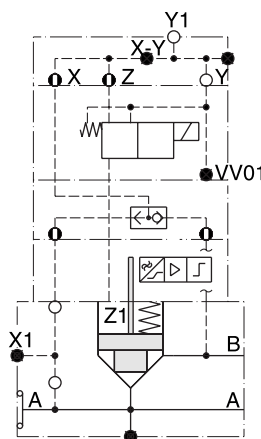

D5S 08 -536-3A.-BH-
10 9 BE
12

Pilot oil: internal from A +
internal from B
Pilot drain: external out of Y1

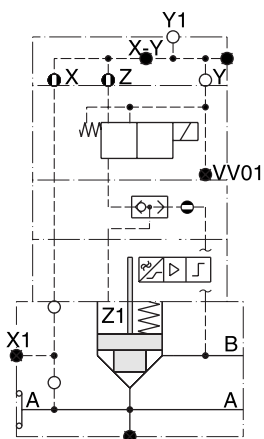

D5S 08 -536-3A.-BN-
10 9 BQ
12

Pilot oil: internal from A +
internal from B
Pilot drain: external out of Y1

Annular entry

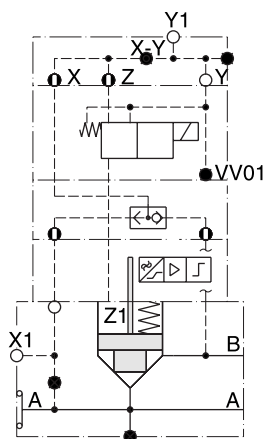

D5S 08 -556-3A.-BH-
10 9 BK
12

Pilot oil: external from X1 +
internal from B
Pilot drain: external out of Y1

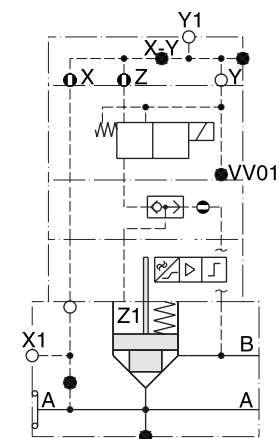

D5S 08 -556-3A.-BN-
10 9 BQ
12

Pilot oil: external from X1 +
internal from B
Pilot drain: external out of Y1

Dimensions

**Directional Seat Valve
Series D5S (Denison)**

Dimensions D5S 2-port

Seat entry

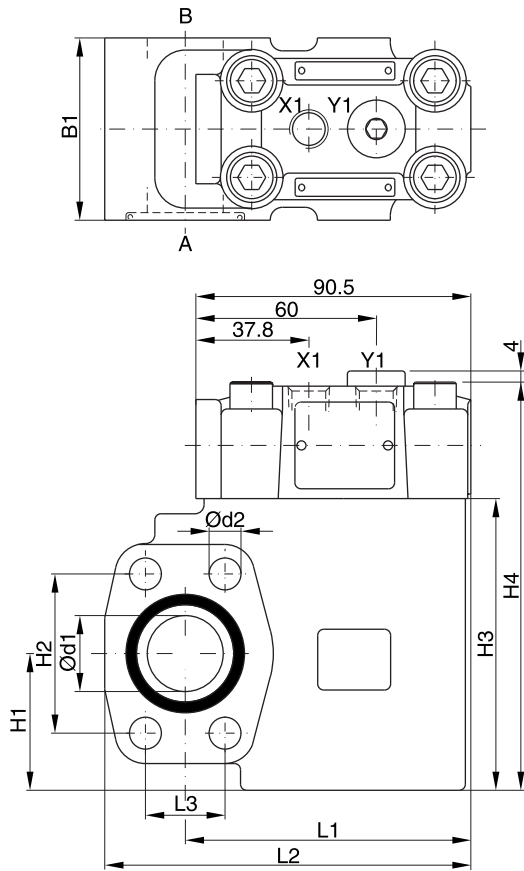

Annular entry

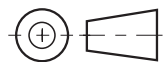
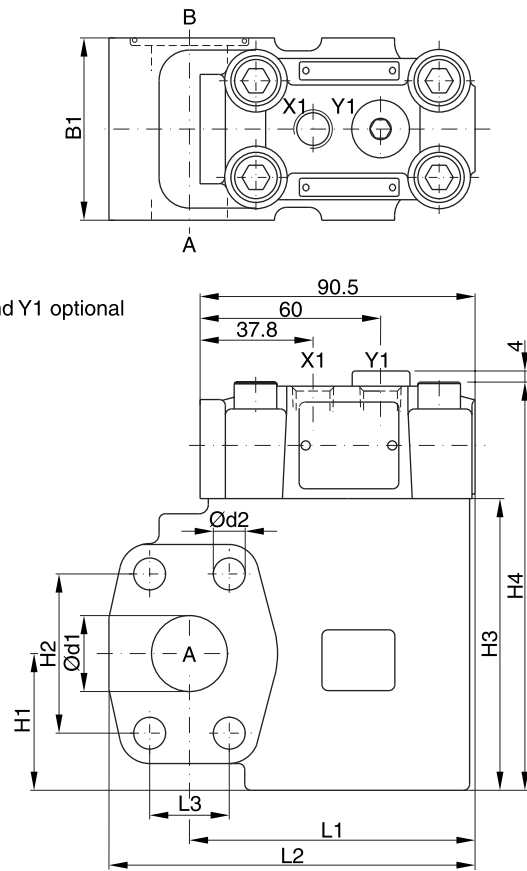

NG	I1	I2	I3	b1	h1	h2	h3	h4	d1	d2
06	77	101.0	22.2	60	37	47.6	90	127.6	19	10.5
08	94	120.5	26.2	60	45	52.4	96	133.6	25	10.5
10	94	128.0	30.2	75	48	58.7	109	146.6	32	12.5

Ports	Function	Port size		
		D5S06	D5S08	D5S10
A	Inlet or outlet	3/4" SAE-61	1" SAE-61	1 1/4" SAE-61
B	Outlet or inlet	3/4" SAE-61	1" SAE-61	1 1/4" SAE-61
X1	External pilot port	G 1/4"		
Y1	External pilot drain			

D5S_UK.INDD RH



Dimensions

Dimensions D5S 3-port

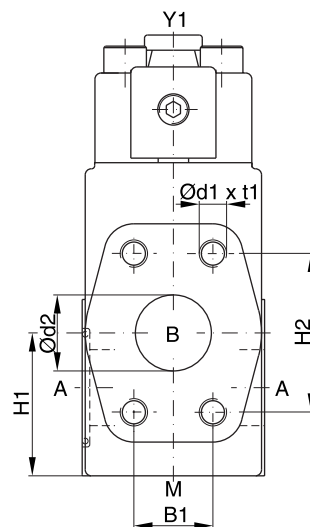
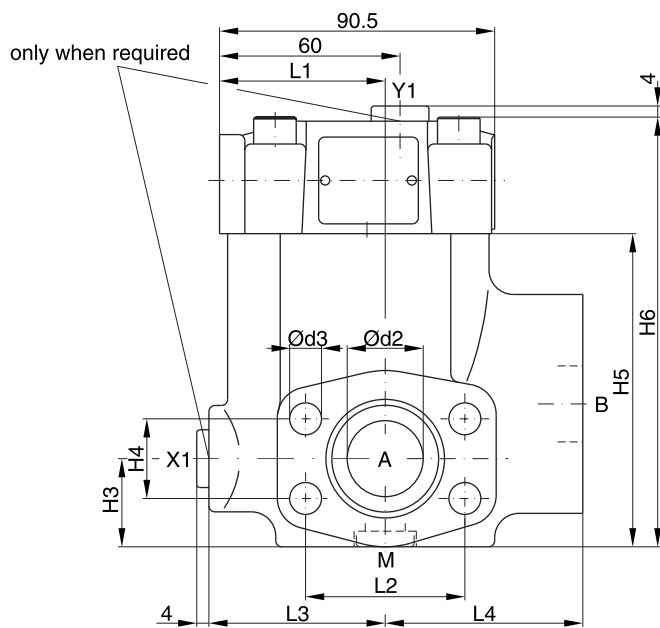
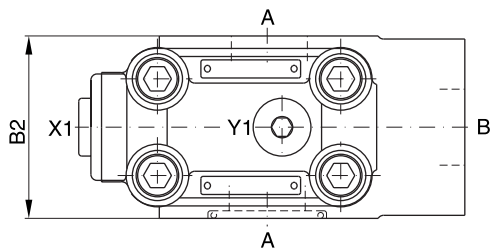

NG	I1	I2	I3	I4	b1	b2	h1	h2	h3	h4	h5	h6	d1	t1	d2	d3
06	49	47.6	56	63	22.2	60	41	47.6	28	22.2	82	119	3/8" UNC	20	19	10.5
08	55	52.4	58	65	26.2	60	47	52.4	29	26.2	103	141	3/8" UNC	23	25	10.5
10	57	58.7	64	61	30.2	75	65	58.7	36	30.2	113	150	7/16" UNC	22	32	12.5
12	37	69.8	55	93	35.7	80	73	69.8	72	35.7	140	178	1/2" UNC	27	38	13.5

Ports	Function	Port size			
		D5S06	D5S08	D5S10	D5S12
A (2x)	Inlet or outlet	3/4" SAE-61	1" SAE-61	1 1/4" SAE-61	1 1/2" SAE-61
B	Outlet or inlet	3/4" SAE-61	1" SAE-61	1 1/4" SAE-61	1 1/2" SAE-61
X1 ¹⁾	External pilot port	G1/4"			
Y1	External pilot drain				
M	Pressure gauge				

¹⁾ closed when supplied

Characteristics

**Proportional Throttle Valve
Series F5C (Denison)**

Proportional throttle valves series F5C allow to adjust the flow in proportion to the input signal. The combination of the F5C with pressure compensators R5A or R5P serves as a flow control valve - providing load compensated flow.

The F5C is offered with two types of response time:
 standard 350 ms at 1 l/min pilot flow
 code A, faster 150 ms at 2 l/min pilot flow

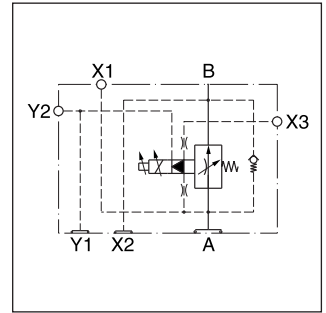
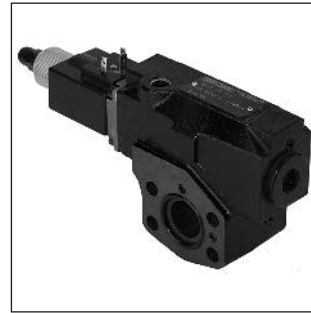

Features

- Spool type proportional throttle valve
- SAE61 flange
- Maximum pressure 270 bar
- Maximum flow 380 l/min
- 3 sizes, SAE 3/4", 1", 1 1/4"
- Load compensated flow in combination with R5A and R5P

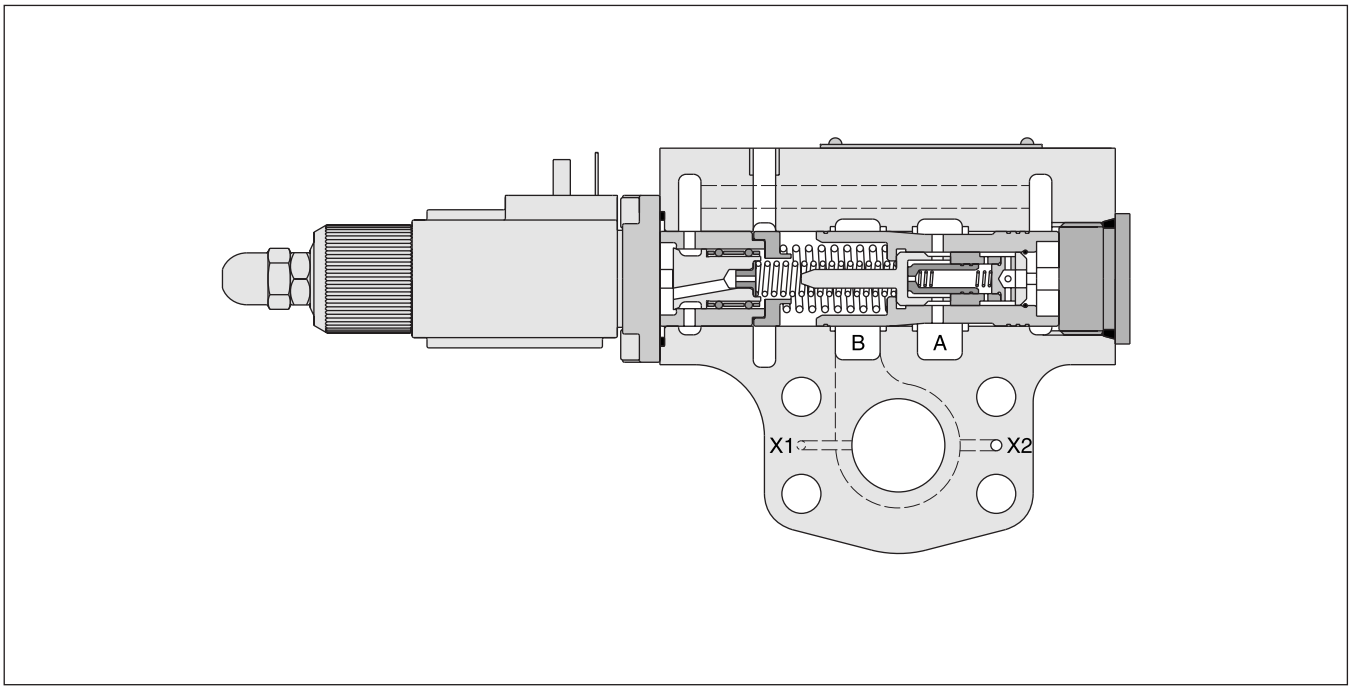

Proportional Throttle Valve Series F5C (Denison)

Ordering Code

F5C			4	3		1		0	A		
Pressure relief valve	Nominal size	Pilot flow and response	SAE61 interface	Pilot ports G $\frac{1}{4}$ "	Spool type	Proportional solenoid	Pilot connection	Accessories	Design series	Seals	Options

Code	Nominal size
06	SAE $\frac{3}{4}$ "
08	SAE 1"
10	SAE $1\frac{1}{4}$ "

Code	Pilot flow	Max. response
omit	1 l/min	350 ms
A	2 l/min	250 ms

Spool type		
Code	Size	Max. flow ¹⁾
A	06	23 l/min
B	06/08	45 l/min
1	06/08/10	95 l/min
2	08/10	190 l/min
3	10	380 l/min

Code	Seals
1	NBR
5	FPM

Code	Pilot connections	F5C without compensators R5A, R5P	F5C for combination with R5A	F5C for combination with R5P
2	internal PD (Y) internal PP (X)			X1, X3, Y2 ● X2, Y1 ○ X2, Y1 ○
3	external PD (Y) external PP (X)		X1, X3, Y2 ○ X2, Y1 ⊗	
4	external PD (Y) external PP (X)	X3, Y2 ○ X1 ● X2, Y1 ⊗		X2, X3, Y1, Y2 ○ X1 ●
5	external PD (Y) internal PP (X)		X1, Y2 ○ X3 ● X2, Y1 ⊗	
6	external PD (Y) internal PP (X)	X1, X3 ● X2, Y1 ⊗ Y2 ○		X1, X3 ● X2, Y1, Y2 ○

¹⁾ At nominal pressure drop ($\Delta p = 8.4\text{bar}$)

9

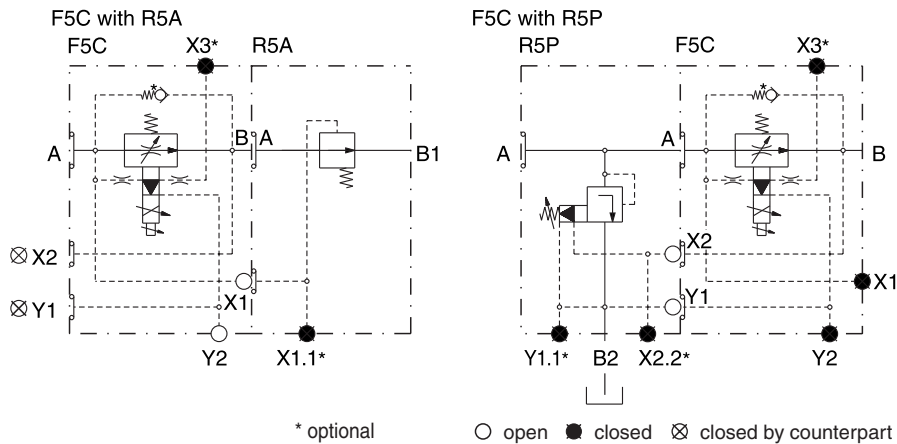

Technical data

General		06 (¾")			08 (1")			10 (1¼")			
		Flanged according to SAE 61 unrestricted									
Size		06 (¾")			08 (1")			10 (1¼")			
Mounting		Flanged according to SAE 61 unrestricted									
Mounting position		unrestricted									
Ambient temperature	[°C]	-20...+50									
Weight	[kg]	3.9			4.1			5.8			
Hydraulic											
Max. operating pressure											
	Ports A, B, X1, X2, X3	[bar]	270								
	Ports Y1, Y2	[bar]	70								
Max. pressure drop (from A to B)		[bar]	21								
Nominal flow	[l/min]	95			190			380			
Fluid		Hydraulic oil as per DIN 51524...525									
Fluid temperature	[°C]	-20...+80									
Viscosity permitted	[cSt] [mm²/s]	10...650									
Viscosity recommended	[cSt] [mm²/s]	30									
Filtration		ISO 4406 (1999) 18/16/13 (acc. NAS 1638: 7)									
Electrical characteristics											
Duty ratio	[%]	100									
Solenoid connection		Connector as per EN175301-803									
Protection class		IP65 in accordance with EN 60529 (plugged and mounted)									
Supply voltage	[V]	12									
Current consumption	[mA]	220									
Resistance	[Ohm]	60									
Response time	[ms]	see ordering code									
Coil insulation class		H (180 °C)									

Characteristic curves

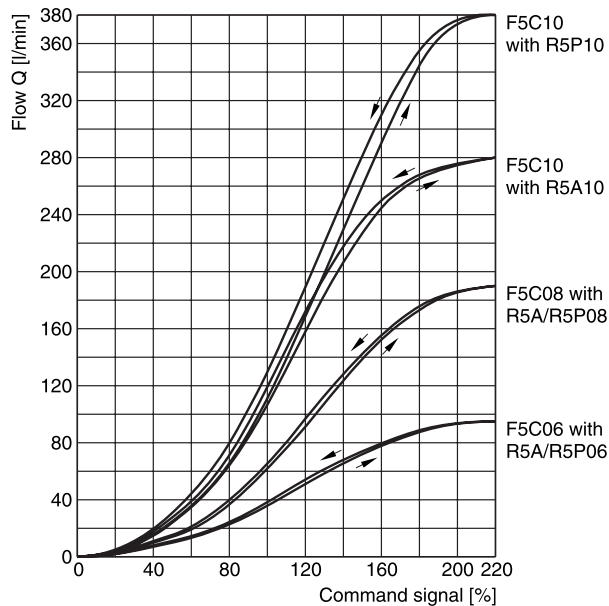

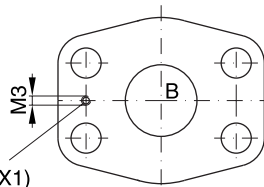

internal pilot pressure connection (X1)
(for use with R5A - 2-port compensator)

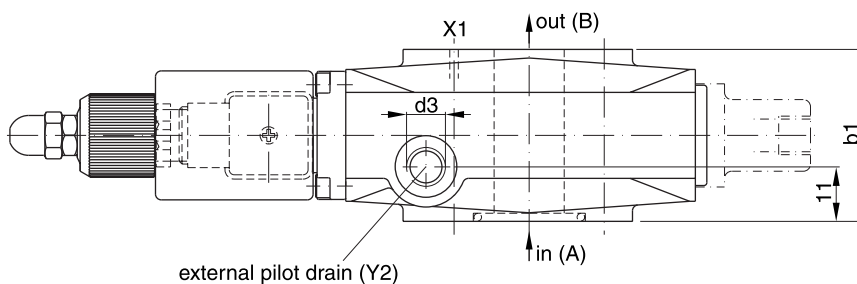

external pilot drain (Y2)

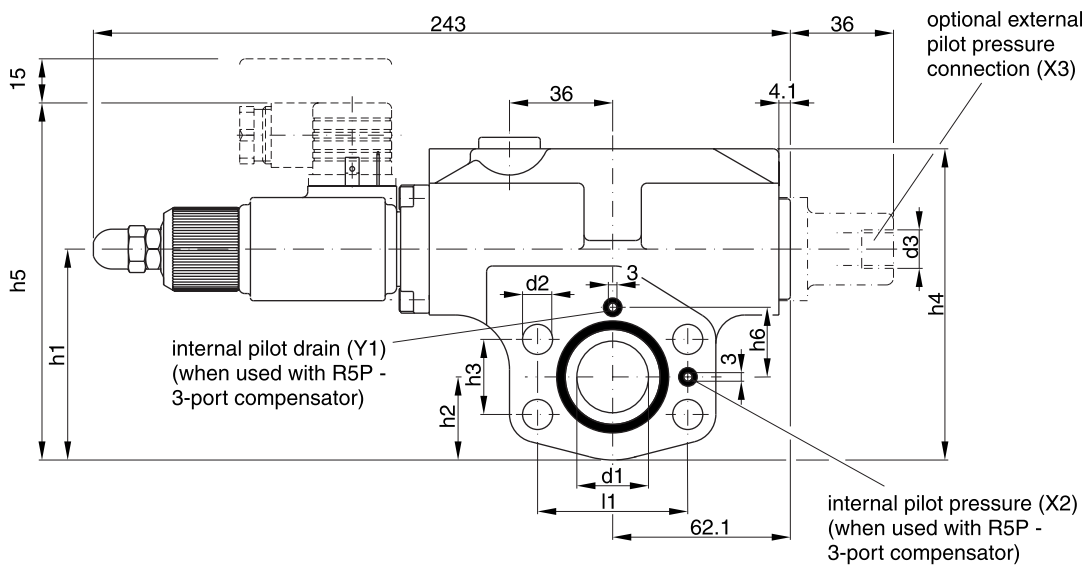

	l1	b1	h1	h2	h3	h4	h5	h6	d1	d2	d3
F5C06	47.6	60	68.2	26	22.2	103.2	119.2	20.8	19	10.5	G¼"
F5C08	52.4	60	73.6	29	26.2	108.6	124.6	24.3	25	10.5	G¼"
F5C10	58.7	75	83.5	36.5	30.2	118.5	134.5	29.3	32	12.5	G¼"

9

Characteristics

Direct operated 2 way pressure compensators series R5A can be combined with any type of fixed or adjustable flow resistor (throttle) to provide a load compensated flow. The combination with the proportional throttle valve F5C serves as a compact 2 way flow control unit in SAE flange design. The R5A is typically used as meter-out compensator behind the flow resistor.

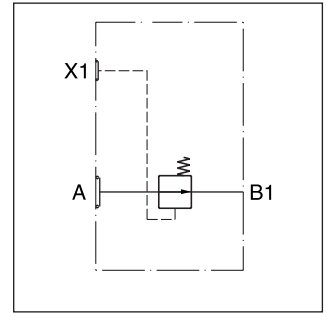

Features

- Seated type 2 way pressure compensator
- SAE61 flange
- 8.4 bar control pressure
- 3 sizes, SAE 3/4", 1", 1 1/4"
- Load compensated flow in combination with F5C

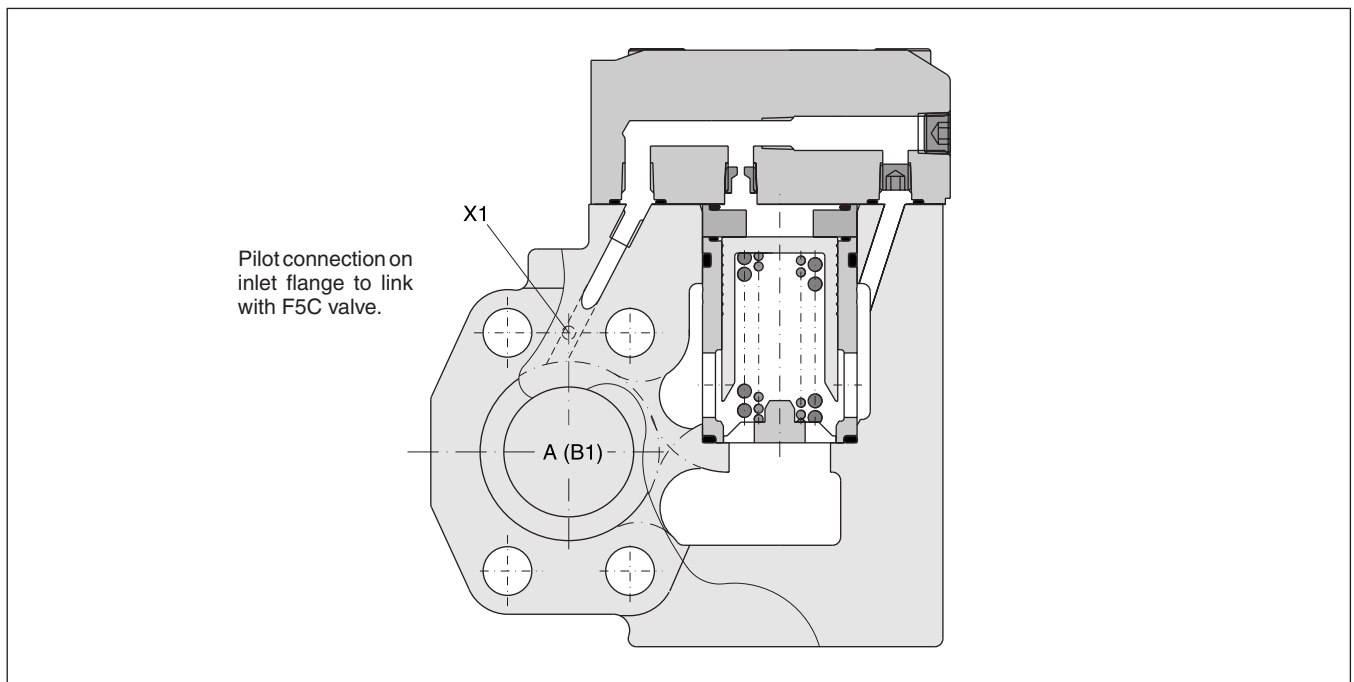

Ordering Code / Technical Data

Ordering code

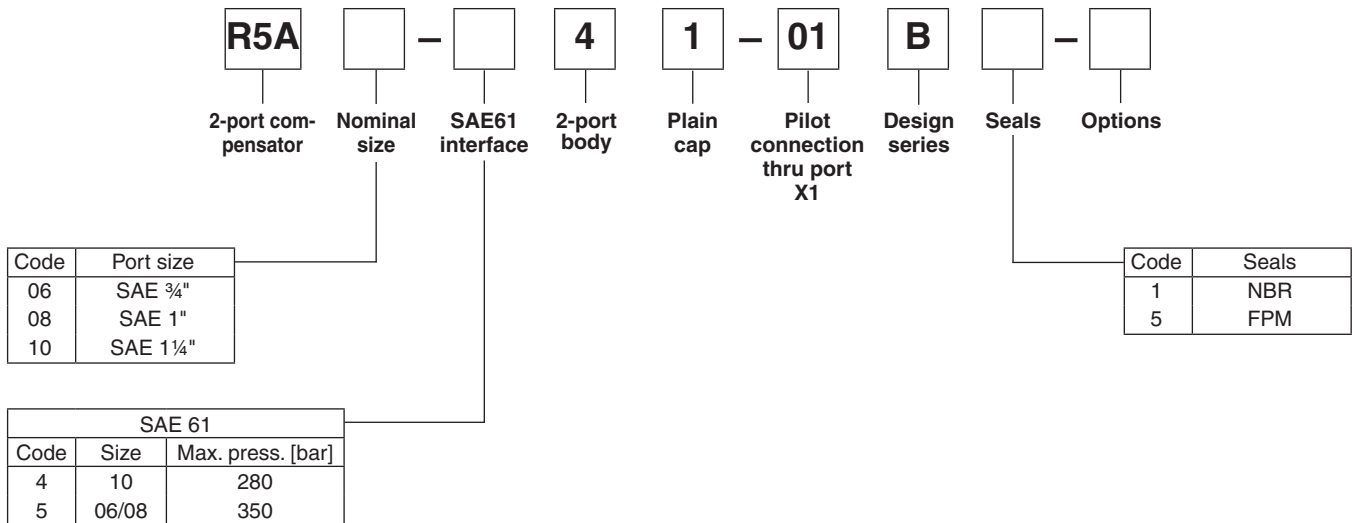

Technical data

General		06 (¾")	08 (1")	10 (1¼")
Size				
Mounting		Flanged according to SAE 61		
Mounting position		unrestricted		
Ambient temperature	[°C]	-20...+50		
Weight	[kg]	3.6	4.3	5.6
Hydraulic				
Max. operating pressure	[bar]			
	Ports A, B, X1	350	350	280
Control pressure	[bar]	8.4		
Nominal flow	[l/min]	90	300	600
Fluid		Hydraulic oil as per DIN 51524...525		
Fluid temperature	[°C]	-20...+80		
Viscosity permitted	[cSt] [mm²/s]	10...650		
Viscosity recommended	[cSt] [mm²/s]	30		
Filtration		ISO 4406 (1999) 18/16/13 (acc. NAS 1638: 7)		

9

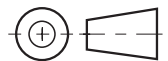
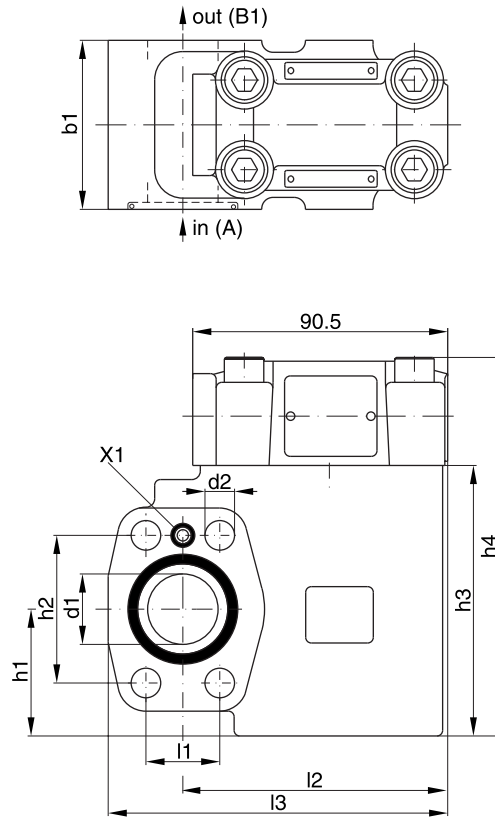

	l1	l2	l3	b1	h1	h2	h3	h4	d1	d2
R5A06	22.2	84	108	60	37	47.6	90	128	19	10.5
R5A08	26.2	101	128	60	45	52.4	96	134	25	10.5
R5A10	30.2	101	135	75	48	58.7	109	147	32	12.5

Characteristics

**3-Port Compensator
Series R5P (Denison)**

Direct operated 3 way pressure compensators series R5P can be combined with any type of fixed or adjustable flow resistor (throttle) to provide a load compensated flow. The combination with the proportional throttle valve F5C serves as a compact 3 way flow control unit in SAE flange design. The R5P is typically used as meter-in compensator in front of the flow resistor.

The R5P is additionally equipped with a pressure relief pilot, that controls the compensator cartridge and operates a system pressure relief valve. The R5P*P2 provides a proportional relief function.

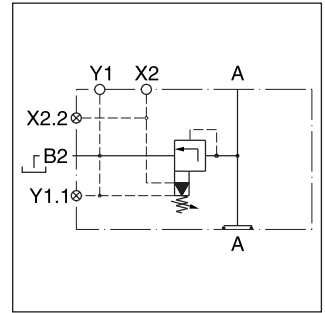

Features

- Seated type 3 way pressure compensator
- SAE61 flange
- 8.4 bar control pressure
- Pressure relief function (optionally proportional)
- With optional vent function
- 3 sizes, SAE 3/4", 1", 1 1/4"
- Load compensated flow in combination with F5C

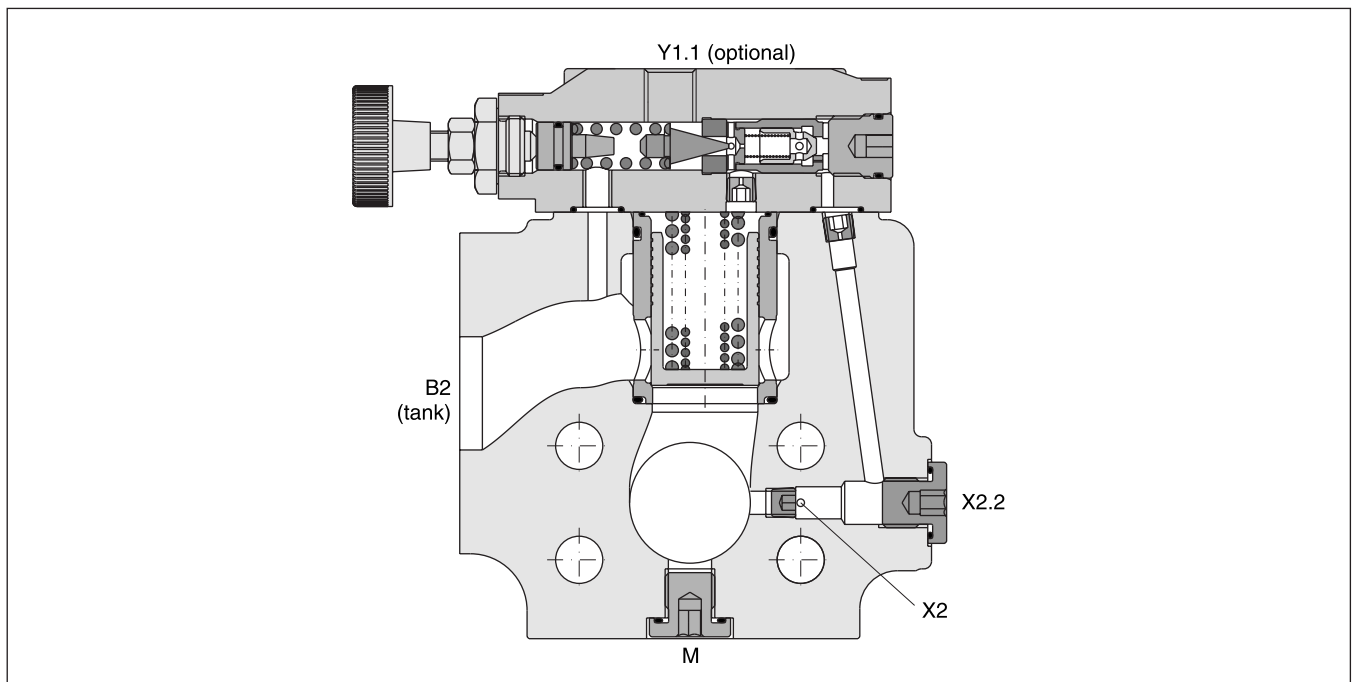

R5P_UK.INDD RH



3-Port Compensator Series R5P (Denison)

Ordering Code

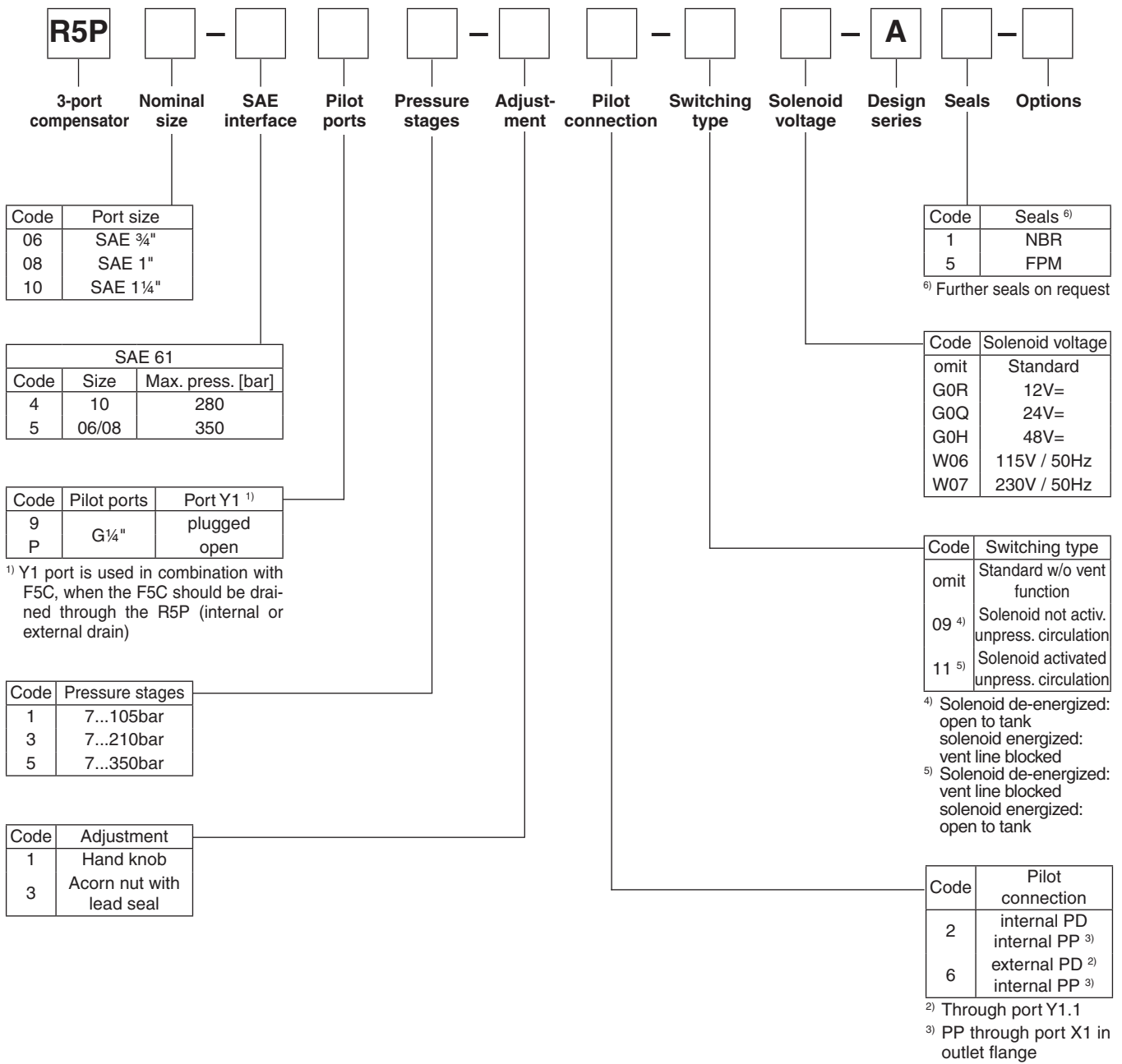

9

3-Port Compensator Series R5P (Denison)

Ordering Code

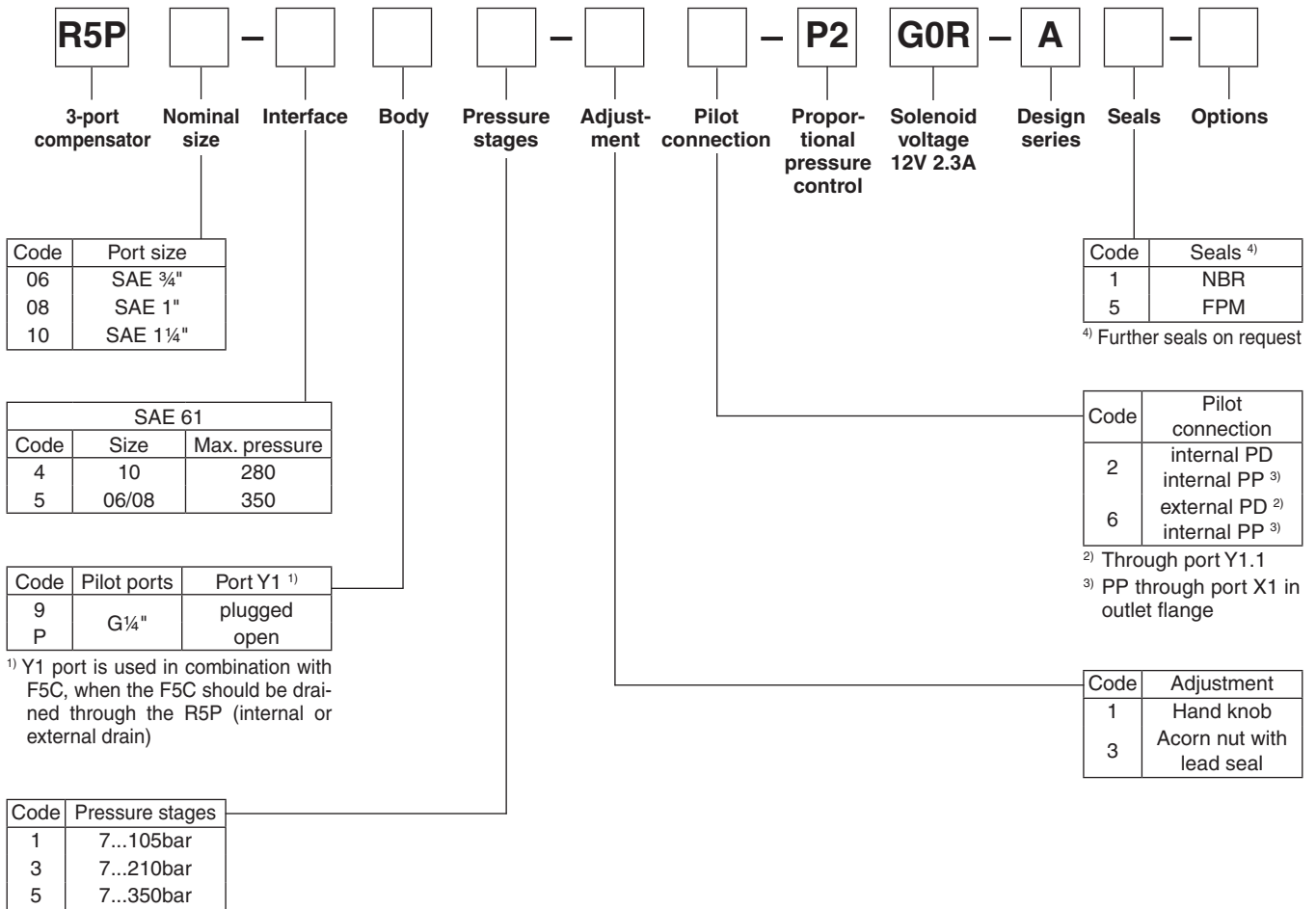

Technical Data

R5P

General		06 (¾")	08 (1")	10 (1¼")		
Size		Flanged according to SAE 61				
Mounting		unrestricted				
Mounting position		unrestricted				
Ambient temperature	[°C]	-20...+50				
Weight	R5P [kg]	3.7	4.4	5.3		
	R5P with VV01 [kg]	5.4	6.1	7.0		
Hydraulic						
Max. operating pressure	[bar]					
	Ports A, B	350	350	280		
Pressure stages	[bar]	105, 210, 350				
Nominal flow	[l/min]	90	300	600		
Fluid		Hydraulic oil as per DIN 51524...525				
Fluid temperature	[°C]	-20...+80				
Viscosity permitted	[cSt] [mm²/s]	10...650				
Viscosity recommended	[cSt] [mm²/s]	30				
Filtration		ISO 4406 (1999) 18/16/13 (acc. NAS 1638: 7)				
Electrical (solenoid) R5P with VV01						
Duty ratio	[%]	100				
Solenoid connection		Connector as per EN175301-803				
Protection class		IP65 in accordance with EN 60529 (plugged and mounted)				
	Code	G0R	G0Q	GAR	GAG	W06 W07
Supply voltage	[V]	12V =	24V =	98V =	205V =	150 at 50Hz 230 at 50Hz
Tolerance supply voltage	[%]	+5...-10	+5...-10	+5...-10	+5...-10	+5...-10 +5...-10
Power consumption	hold [W]	31	31	31	31	78 78
	in rush [W]	31	31	31	31	264 264
Response time	[ms]	Energized / De-energized AC: 20/18 , DC: 46/27				
Max. switching frequency		AC: up to 7200, DC: up to 16000 switchings/hour				
Coil insulation class		H (180 °C)				

R5P*P2

General		06 (¾")	08 (1")	10 (1¼")		
Size		Flanged according to SAE 61				
Mounting		unrestricted				
Mounting position		unrestricted				
Ambient temperature	[°C]	-20...+50				
	[kg]	5.5	6.2	7.1		
Hydraulic						
Max. operating pressure	Ports A, B [bar]	350	350	280		
Pressure stages	[bar]	105, 210, 350				
Nominal flow	[l/min]	90	300	600		
Fluid		Hydraulic oil as per DIN 51524...525				
Fluid temperature	[°C]	-20...+80				
Viscosity permitted	[cSt] [mm²/s]	10...650				
Viscosity recommended	[cSt] [mm²/s]	30				
Filtration		ISO 4406 (1999) 18/16/13 (acc. NAS 1638: 7)				
Electrical (proportional solenoid)						
Duty ratio	[%]	100				
Nominal voltage	[V]	12				
Max. current	[A]	2.3				
Coil resistance	[Ohm]	4 at 20°C				
Solenoid connection		Connector as per EN175301-803				
Protection class		IP65 in accordance with EN 60529 (plugged and mounted)				
Power amplifier		PCD00A-400				

R5P

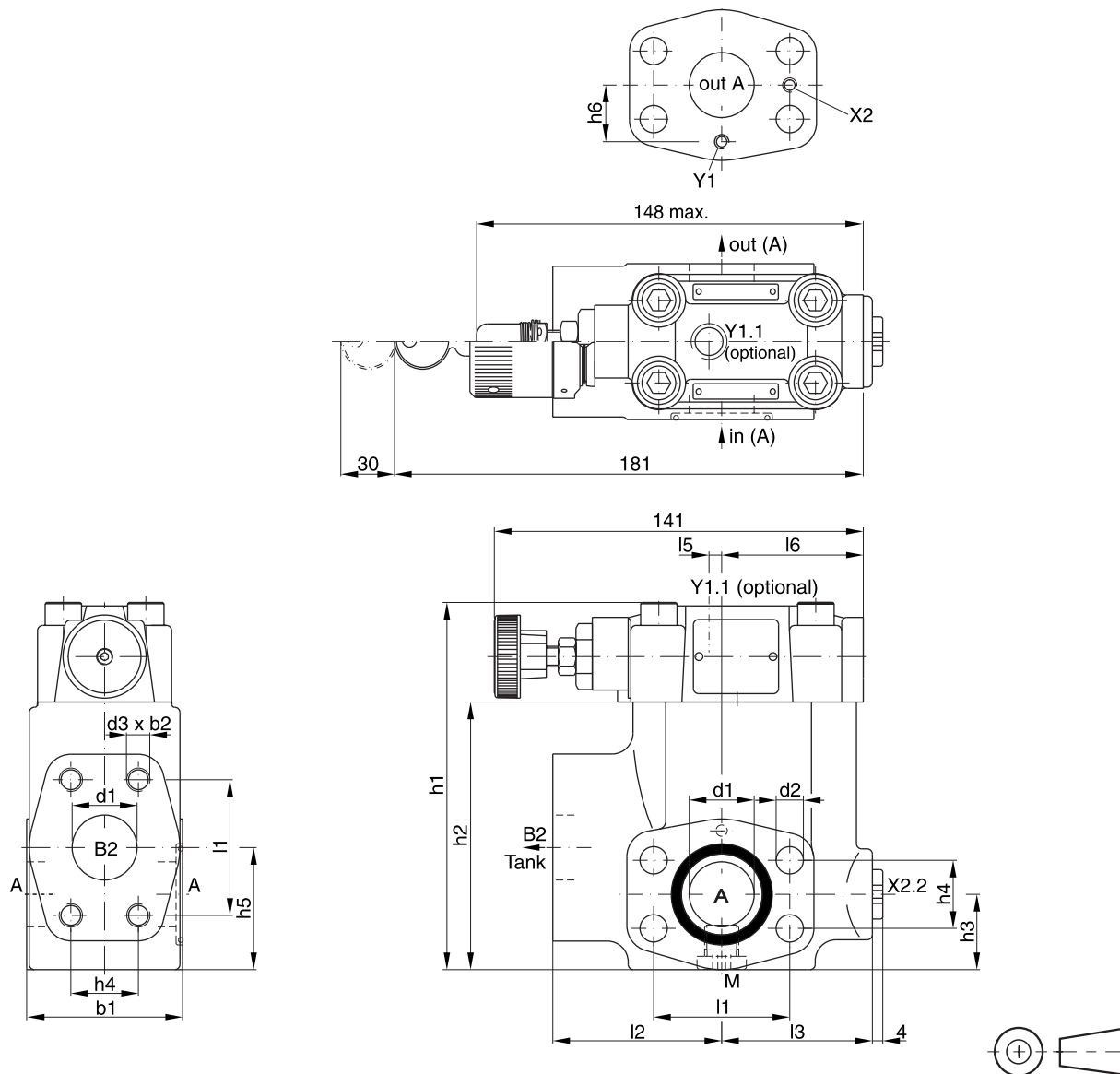

	I1	I2	I3	I4	I5	I6	b1	b2	h1	h2	h3	h4	h5	h6	d1	d2	d3
R5P06	47.6	63	56	148	1	49	60	20	119	81.6	28.6	22.2	41.6	20.8	19	10.5	3/8" UNC
R5P08	52.4	65	58	144.6	5	54.5	60	23	142	103	30.6	26.2	48.6	24.3	25	10.5	3/8" UNC
R5P10	58.7	61	62	146.6	3	56.5	75	22	149	111.5	34.6	30.2	64.1	29.3	32	12.5	7/16" UNC

Ports

Port	Function	Port size		
		R5P06	R5P08	R5P10
A	Inlet/outlet	3/4"	1"	1 1/4"
B2	Tank	3/4"	1"	1 1/4"
X2	Internal pilot pressure	M3		
X2.2	External pilot pressure	G 1/4"		
Y1	Internal pilot drain	M3		
Y1.1	External pilot drain	G 1/4"		
M	Pressure gauge	G 1/4"		

R5P*P2

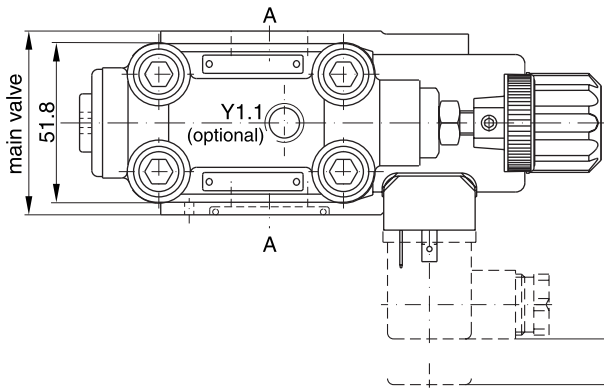

Drain line only external from the pilot head (Y1.1).
 The pilot drain port must be connected to a stable low pressure tank line. Pressure variations in the drain port should be avoided.

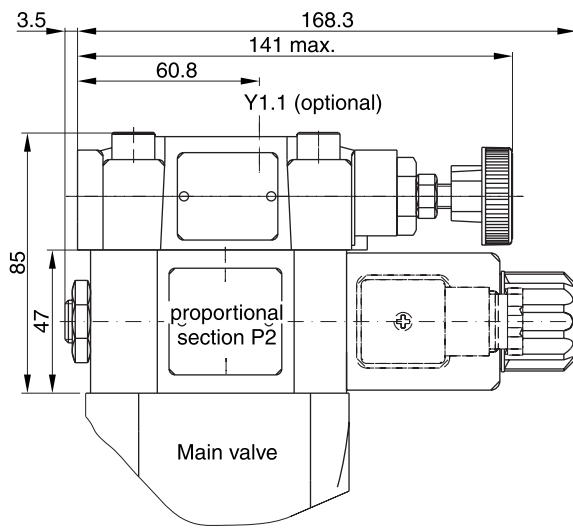

Note
 On initial start up and after long shut down periods bleed air from this plug.

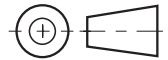

R5P with vent function

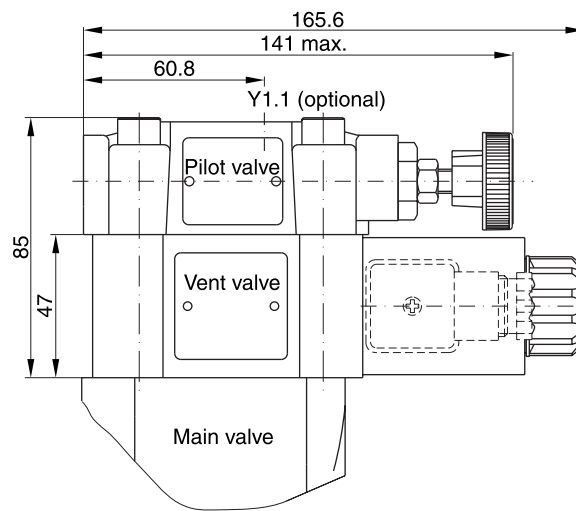
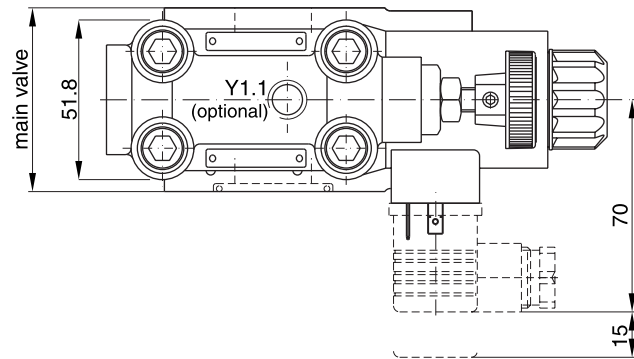

Code	Internal drain	External drain
11		
09		

R5P_UK.INDD RH

Characteristics

Direct operated check valves series C5V provide free flow in one direction and block the flow in the counter direction.

The SAE flanges allow to mount the C5V directly on the pressure port of pumps for protection against pressure shocks from the system.

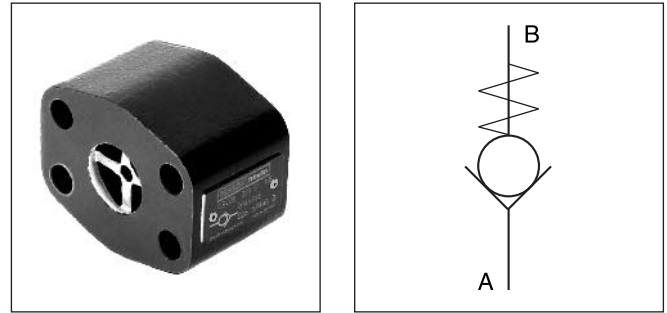

Features

- Direct operated check valve
- SAE61 and SAE62 flange
- 4 sizes (SAE 3/4", 1", 1 1/4", 1 1/2")
- 3 springs
- 2 different seal configurations

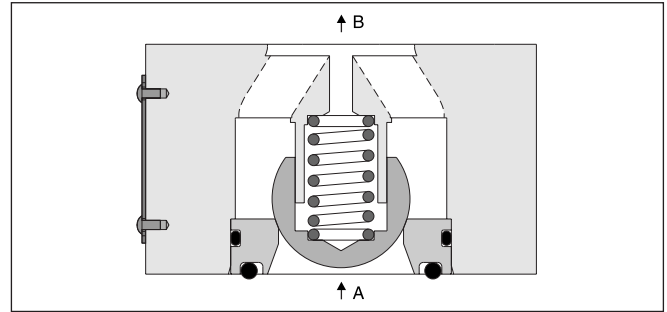

Technical data

General		06 (3/4")	08 (1")	10 (1 1/4")	12 (1 1/2")
Size		06 (3/4")	08 (1")	10 (1 1/4")	12 (1 1/2")
Mounting		2-port inline flange (SAE61 and 62)			
Mounting position		unrestricted			
Ambient temperature	[°C]	-20...+50			
Weight	[kg]	0.6	0.9	1.3	1.8
Hydraulic					
Max. operating pressure	[bar]				
	SAE61	350	350	280	210
	SAE62	420	420	420	—
Pressure stages	[bar]				
Nominal flow	[l/min]	100	200	400	750
Fluid		Hydraulic oil as per DIN 51524...525			
Fluid temperature	[°C]	-20...+80			
Viscosity permitted	[cSt]/[mm²/s]	10...650			
Viscosity recommended	[cSt]/[mm²/s]	30			
Filtration		ISO 4406 (1999) 18/16/13 (acc. NAS 1638: 7)			

Direct Operated Check Valve Series C5V (Denison)

Ordering Code

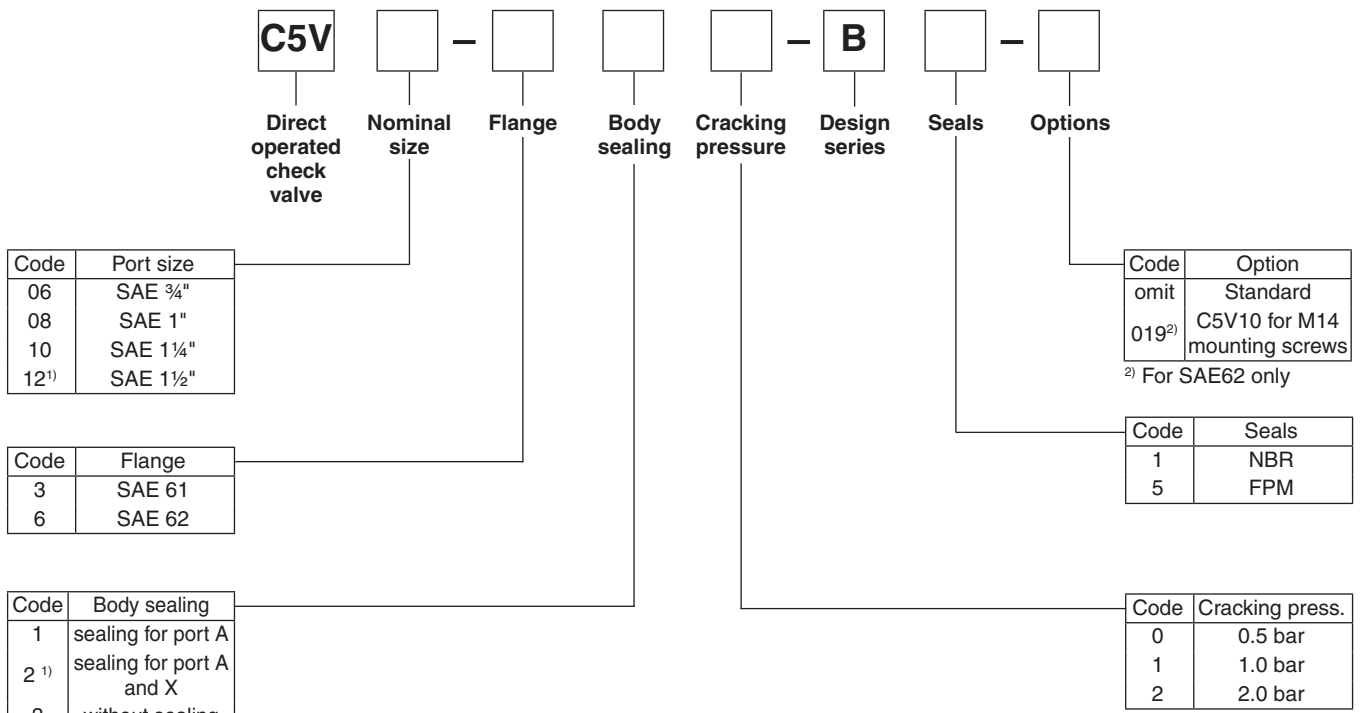

¹⁾ For combination with R5U unloading valve (SAE61 only)

C5V06

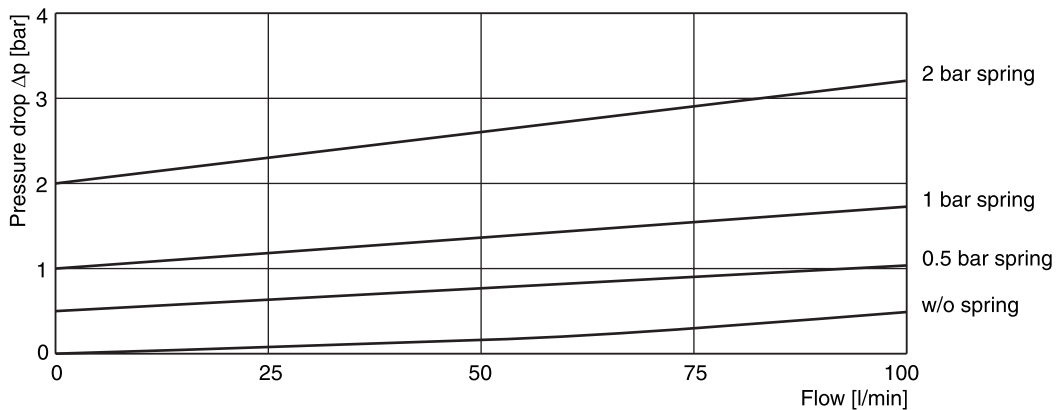

C5V08

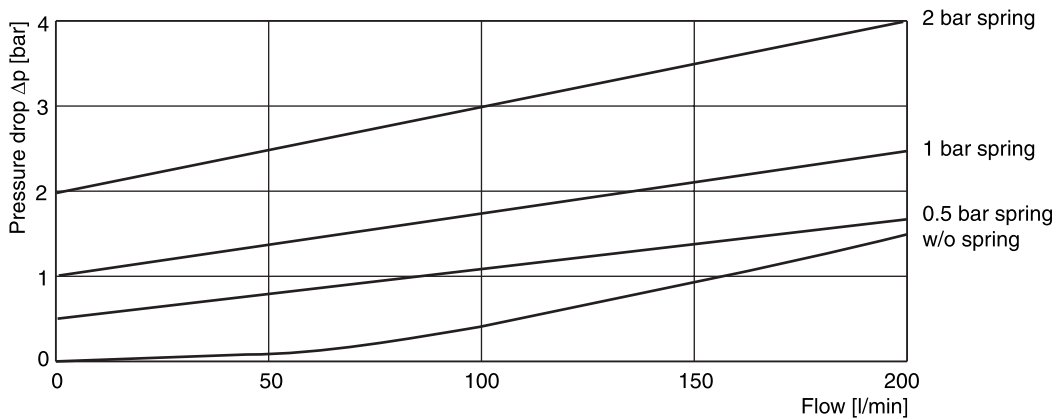

C5V10

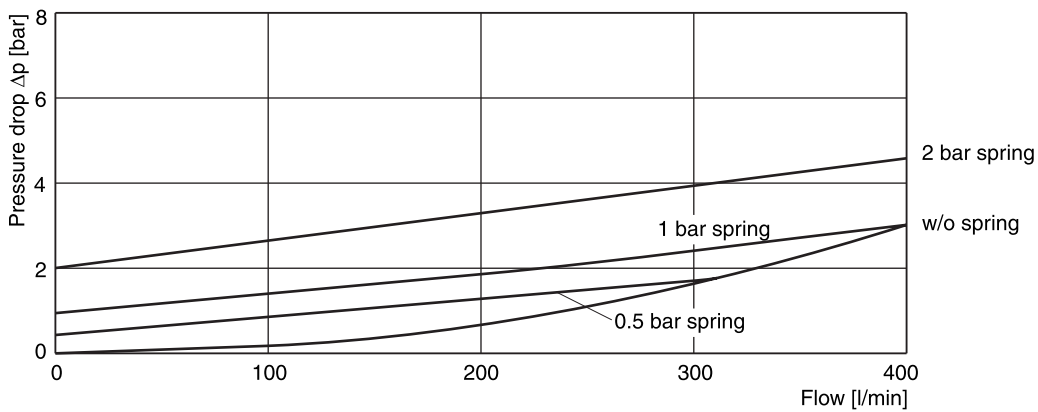

C5V12

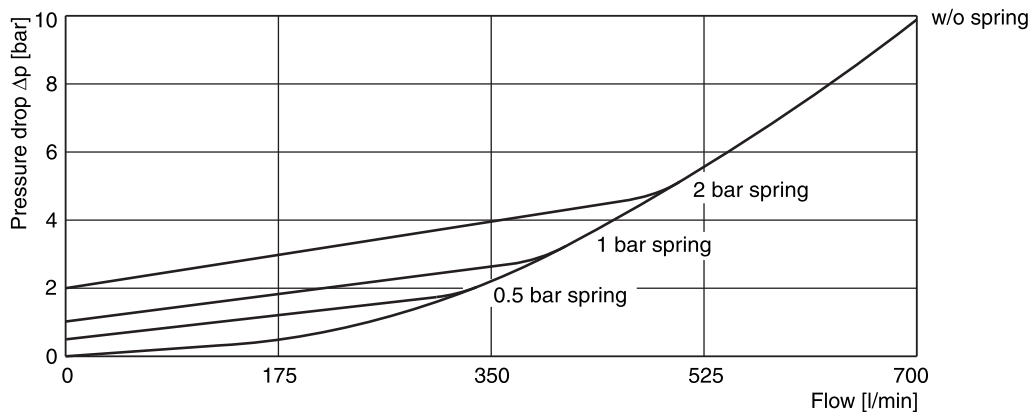

Dimensions

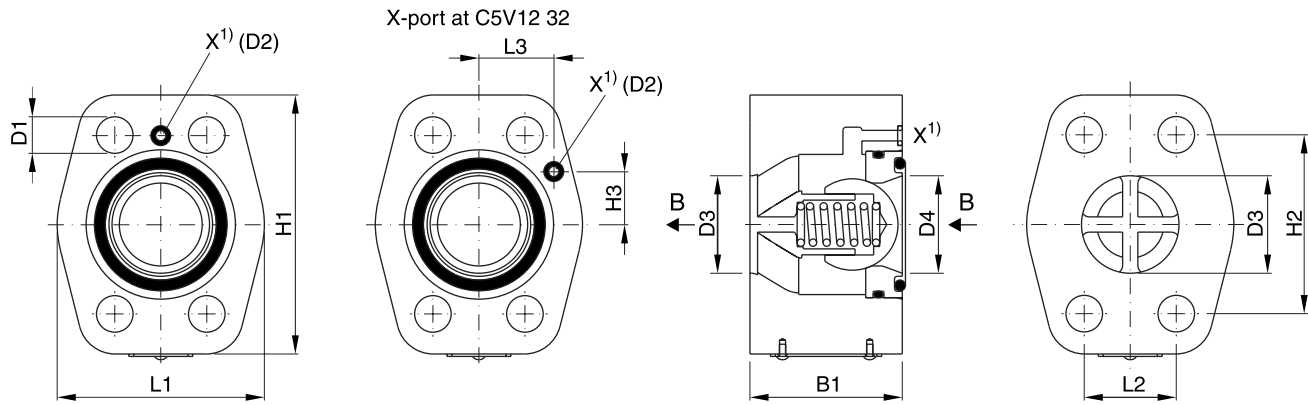

¹⁾ X1 port for C5V*32* (for use with Unloading Valve R5U)

Series	Nominal Size		L1	L2	L3	H1	H2	H3	B1	D1	D2	D3 + 0.8	D4
C5V06	3/4"	SAE61	48	22.2	27.2	64	47.6	22.4	45	10.5	Ø3	19	19
		SAE62	48	23.8	27.2	64	50.8	22.4	45	10.5	-	19	19
C5V08	1"	SAE61	60	26.2	27.2	74	52.4	22.4	45	10.5	Ø3	25	25
		SAE62	60	27.8	27.2	74	57.2	22.4	45	12.5	-	25	25
C5V10	1 1/4"	SAE61	68	30.2	27.2	85	58.7	22.4	50	12.5	Ø3	32	32
		SAE62	68	31.8	27.2	85	66.7	22.4	50	13.5 ²⁾	-	32	32
C5V12	1 1/2"	SAE61	80	35.7	27.2	104	69.8	22.4	50	13.5	Ø3	42	38
		SAE62	80	36.5	27.2	104	79.4	22.4	50	17	-	42	38

²⁾ D1 = 15 at option code 019 for M14 mounting screws

Characteristics

**Pilot Operated Check Valve
Series C5P (Denison)**

Pilot operated check valves series C5P have a similar design to the subplate mounted C4V series. The SAE flanges allow to mount directly on the flanges of actuators to achieve a very compact design.

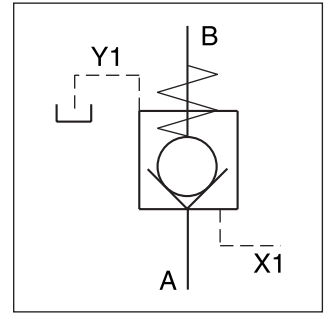

Features

- Pilot operated check valve
- 2-port body with SAE61 flange
- 3 sizes (SAE 3/4", 1", 1 1/4")
- 4 opening ratios

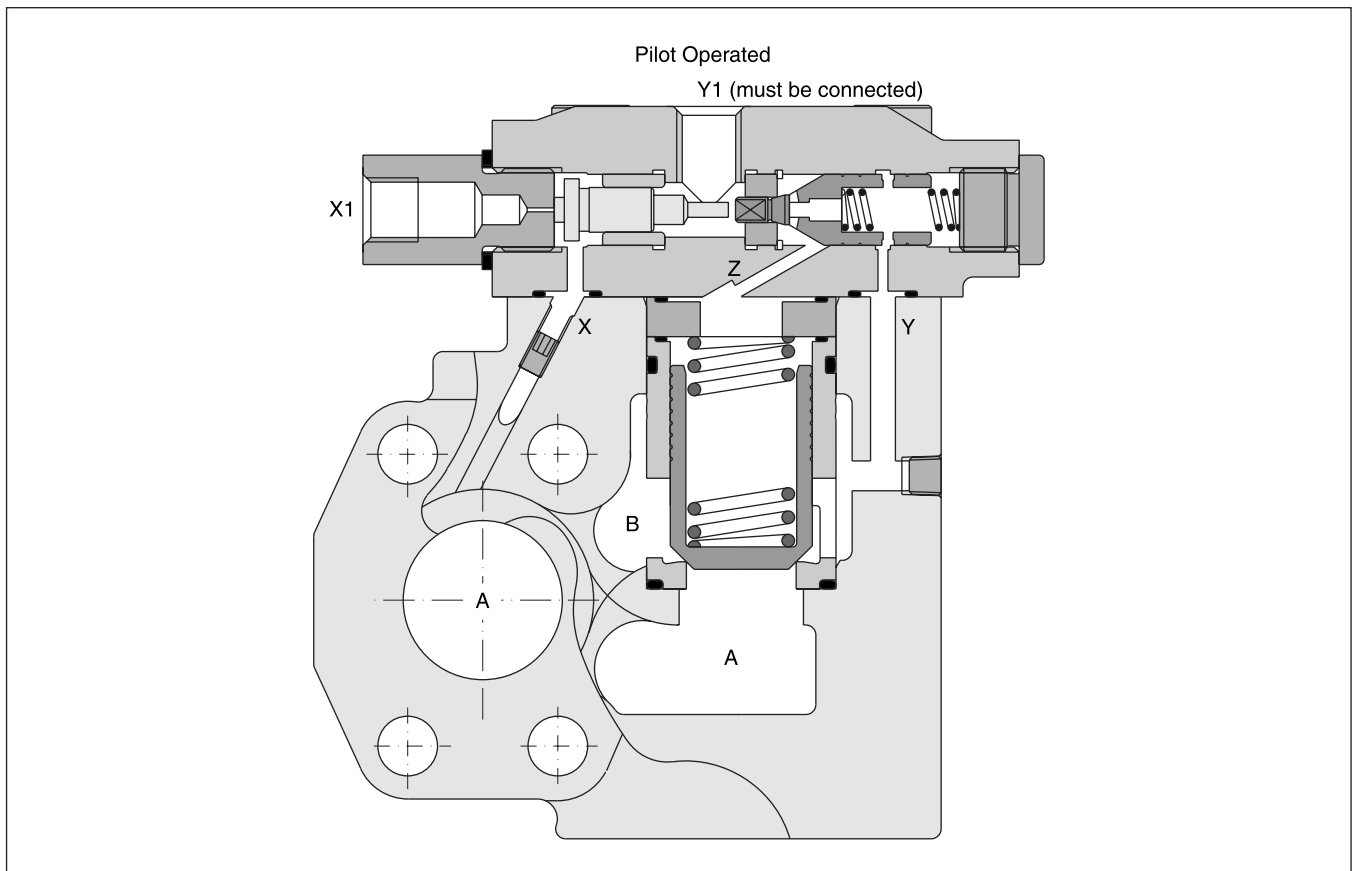

Ordering Code / Technical Data

Ordering code

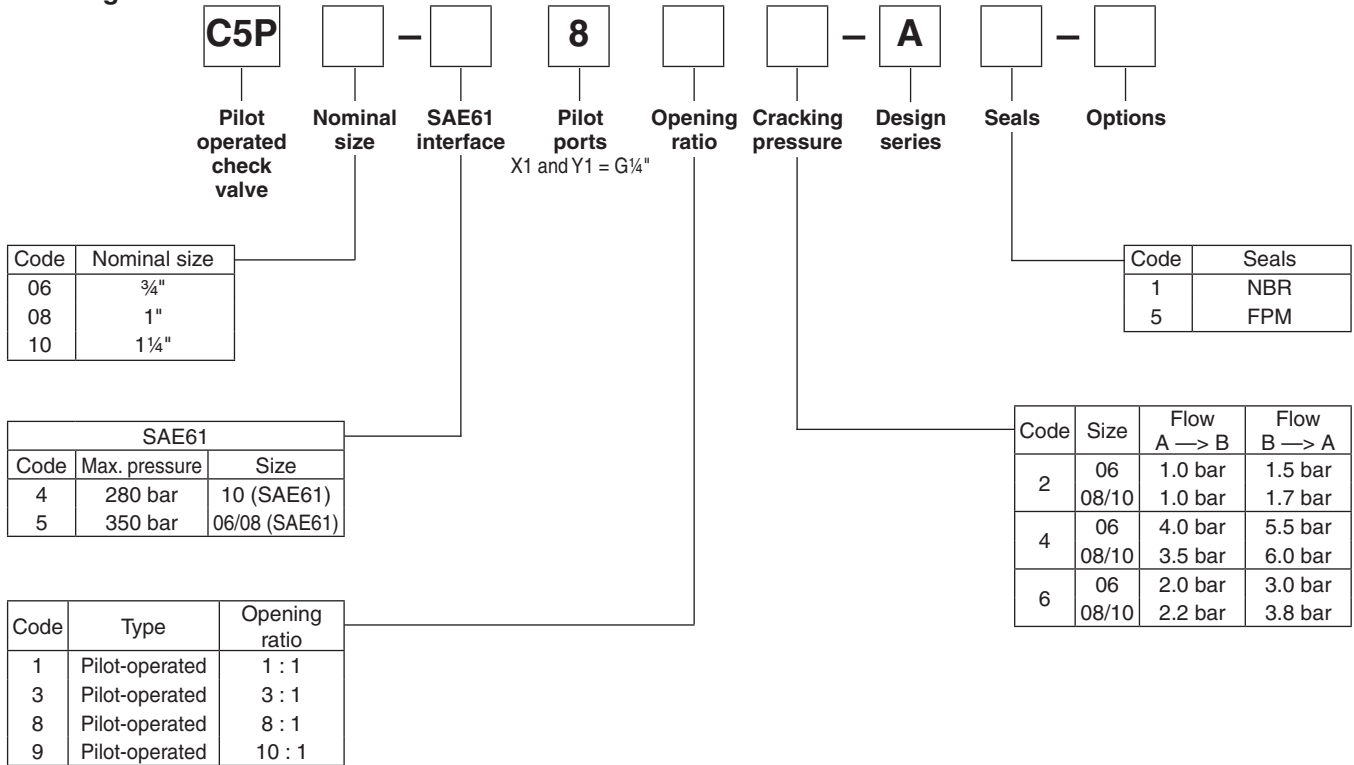

Technical data

General		06 (3/4")	08 (1")	10 (1 1/4")
Size				
Mounting		2-port inline flange (SAE61)		
Mounting position		unrestricted		
Ambient temperature	[°C]	-20...+50		
Weight	pilot-operated [kg]	3.9	4.4	5.7
Hydraulic				
Max. operating pressure	[bar]			
	Ports A, B	350	350	280
	Port Y1	30	30	30
Pressure stages	[bar]			
Nominal flow	[l/min]	180	360	600
Fluid		Hydraulic oil as per DIN 51524...525		
Fluid temperature	[°C]	-20...+80		
Viscosity permitted	[cSt]/[mm²/s]	10...650		
Viscosity recommended	[cSt]/[mm²/s]	30		
Filtration		ISO 4406 (1999) 18/16/13 (acc. NAS 1638: 7)		

C5P_UK.INDD RH



p/Q-performance curves

C5P06

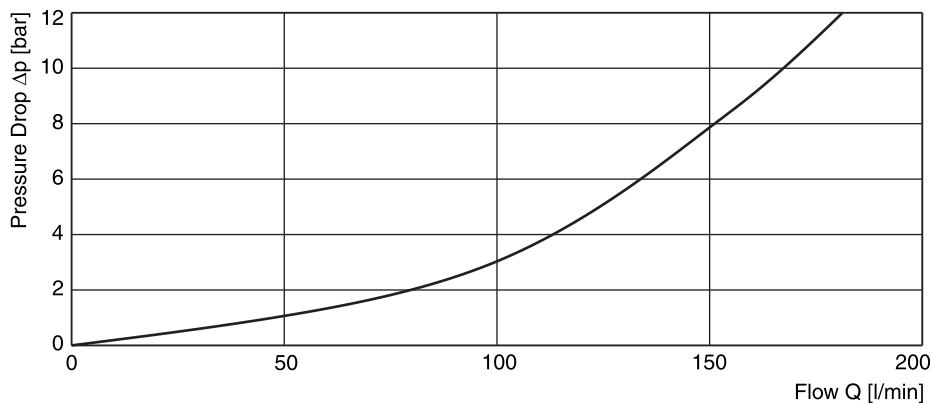

C5P08

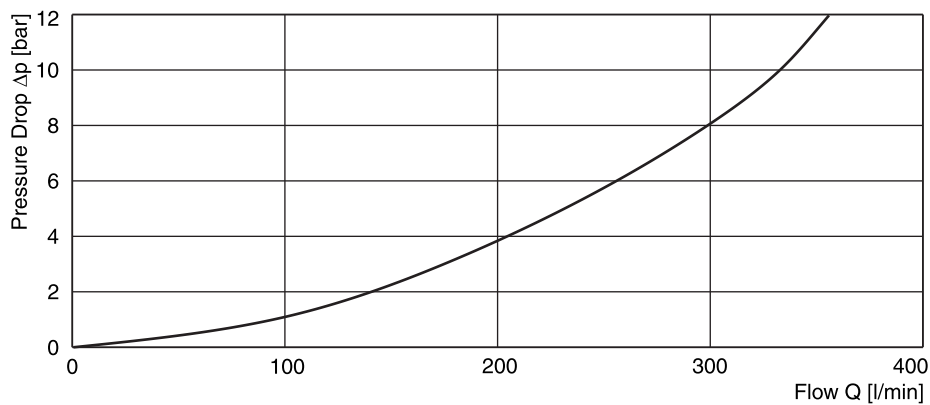

C5P10

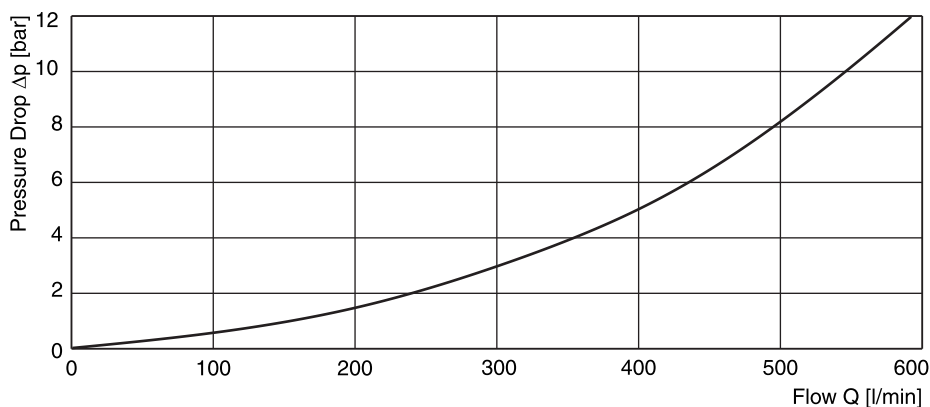

Fluid viscosity 40cSt at 50°C

Dimensions

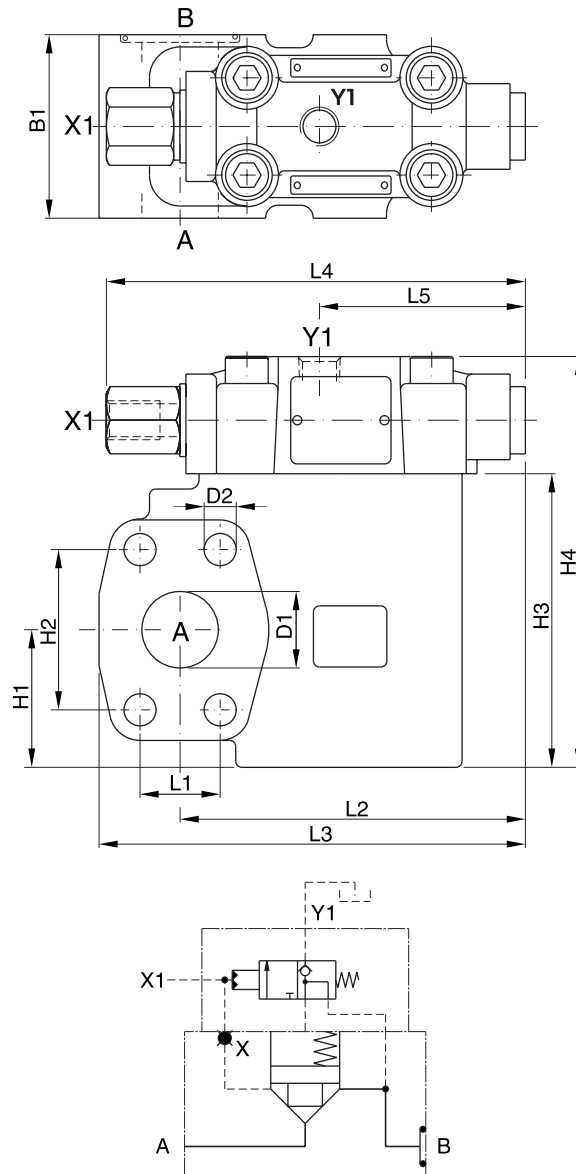

9

Dimensions

Type	L1	L2	L3	L4	L5	B1	H1	H2	H3	H4	D1	D2
C5P06	22.2	95.8	119.8	137	67.3	60	37	47.6	90	128	19	10.5
C5P08	26.2	112.9	139.4	137	67.3	60	45	52.4	96	134	25	10.5
C5P10	30.2	112.9	146.9	137	67.3	75	48	58.7	109	147	32	12.5

Ports

Port	Function	Port size		
		C5P06	C5P08	C5P10
A	Inlet or outlet	¾" SAE61	1" SAE61	1¼" SAE61
B	Outlet or inlet	¾" SAE61	1" SAE61	1¼" SAE61
X1	External pilot port	G¼"		
Y1	External pilot drain	G¼"		

C5P_UK.INDD RH



BK bolt kits for SAE61 valves

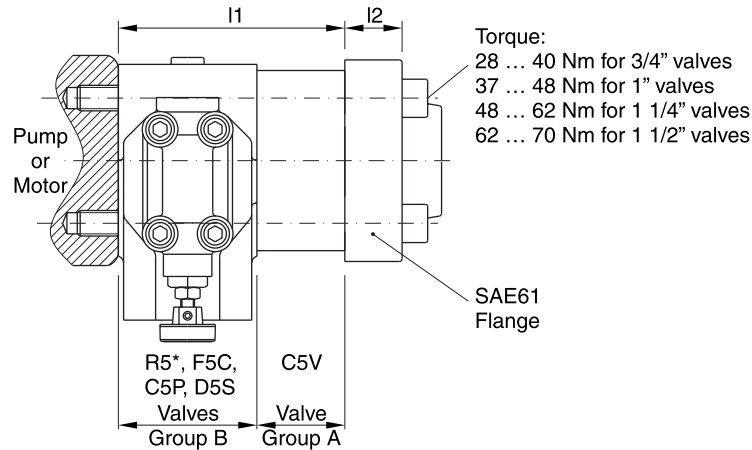

Port	Qty. of valves and group for each stack	I1	I2	UNC screws (12.9)	
				Dimension	Ordering code
3/4" SAE61	1 x A	45	16...22	3/8"-16 x 3/4"	BK-358-16330-0
	1 x B	60		3/8"-16 x 3/4"	BK-358-16350-0
	(1 x A) + (1 x B)	105		3/8"-16 x 5/2"	BK-358-16420-0
	2 x B	120		3/8"-16 x 6"	BK-358-16440-0
1" SAE61	1 x A	45	18...24	3/8"-16 x 3/4"	BK-358-16330-0
	1 x B	60		3/8"-16 x 3/4"	BK-358-16350-0
	(1 x A) + (1 x B)	105		3/8"-16 x 5/4"	BK-358-16430-0
	2 x B	120		3/8"-16 x 6/4"	BK-358-16450-0
1 1/4" SAE61	1 x A	50	21...25	7/16"-14 x 3/2"	BK-358-18340-0
	1 x B	75		7/16"-14 x 4/2"	BK-358-18380-0
	(1 x A) + (1 x B)	125		7/16"-14 x 6/2"	BK-358-18460-0
	2 x B	150		7/16"-14 x 7/2"	BK-358-18500-0
1 1/2" SAE61	1 x A	50	25...27	1/2"-13 x 3/4"	BK-358-20350-0
	1 x B	80		1/2"-13 x 5"	BK-358-20400-0
	(1 x A) + (1 x B)	130		1/2"-13 x 6/4"	BK-358-20470-0
	2 x B	160		1/2"-13 x 8"	BK-358-20520-0

1 bolt kit contains 4 screws.

BK bolt kits for SAE62 valves

Series	Nominal size	I1	I2	Metric screws (12.9)	
				Dimension	Ordering code
C5V06	3/4"	45	21	3/8"-16 x 3/4"	BK-358-16330-0
C5V08	1"	45	25	7/16"-14 x 3/2"	BK-358-18340-0
C5V10	1 1/4"	50	27	1/2"-13 x 3/4"	BK-358-20350-0
R5V06-6	3/4"	60	21	3/8"-16 x 3/4"	BK-358-16350-0
R5V08-6	1"	60	25	7/16"-14 x 3/4"	BK-358-18350-0
R5V10-6	1 1/4"	75	27	1/2"-13 x 4/2"	BK-358-20380-0
R5V12-6	1 1/2"	80	30	5/8"-11 x 5/4"	BK-358-24410-0

Inlet flange

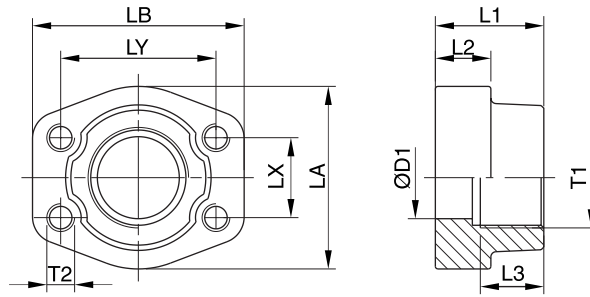

Port size	Inlet flange										
	Order no.	D1	L1	L2	L3	LA	LB	LX	LY	T2	Seal
SAE61											
G $\frac{3}{4}$ "	PCFF33GSU	19	36	18	19	49	66	22.3	47.6	3/8" UNC	NBR: OR25X3.53X FPM: OR25X3.53VITX
G1"	PCFF34GSU	25	38	18	19	53	71	26.2	52.4	3/8" UNC	NBR: OR32.92X3.53X FPM: OR32.92X3.53VITX
G1 $\frac{1}{4}$ "	PCFF35GSU	31	41	21	22	69	80	30.2	58.7	7/16" UNC	NBR: OR37.69X3.53X FPM: OR37.69X3.53VITX
G1 $\frac{1}{2}$ "	PCFF36GSU	38	44	25	24	77	94	35.7	69.9	1/2" UNC	NBR: OR47.22X3.53X FPM: OR47.22X3.53VITX
SAE62											
G $\frac{3}{4}$ "	PCFF63GSU	19	36	19	22	53	71	23.8	50.8	3/8" UNC	NBR: OR25X3.53X FPM: OR25X3.53VITX
G1"	PCFF64GSU	25	44	24	24	69	80	27.8	57.2	7/16" UNC	NBR: OR32.92X3.53X FPM: OR32.92X3.53VITX
G1 $\frac{1}{4}$ "	PCFF65GSU	31	44	27	25	77	94	31.8	66.6	1/2" UNC	NBR: OR37.69X3.53X FPM: OR37.69X3.53VITX
G1 $\frac{1}{2}$ "	PCFF66GSU	38	51	30	28	89	106	36.5	79.3	5/8" UNC	NBR: OR47.22X3.53X FPM: OR47.22X3.53VITX

Outlet and tank port flange

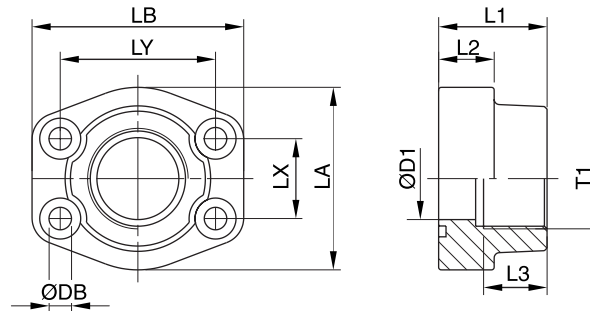

Port size	Outlet and tank port flange										
	Order no.	D1	L1	L2	L3	LA	LB	LX	LY	DB	Srews
SAE61											
G $\frac{3}{4}$ "	PFF33GSU	19	36	18	18	49	66	22.3	47.6	10.5	3/8" x 1 1/2 UNC
G1"	PFF34GSU	25	38	18	20	53	71	26.2	52.4	10.5	3/8" x 1 1/2 UNC
G1 $\frac{1}{4}$ "	PFF35GSU	31	41	21	22	69	80	30.2	58.7	10.5	7/16" x 1 1/2 UNC
G1 $\frac{1}{2}$ "	PFF36GSU	38	44	25	24	77	94	35.7	69.9	13.5	1/2" x 1 3/4 UNC
SAE62											
G $\frac{3}{4}$ "	PFF63GSU	19	36	19	18	53	71	23.8	50.8	10.5	3/8" x 1 1/2 UNC
G1"	PFF64GSU	25	44	24	20	69	80	27,8	57,2	10.5	7/16" x 1 1/2 UNC
G1 $\frac{1}{4}$ "	PFF65GSU	31	44	27	22	77	94	31.8	66.6	15.0	1/2" x 1 3/4 UNC
G1 $\frac{1}{2}$ "	PFF66GSU	38	51	30	24	89	106	36.5	79.3	17.0	5/8" x 2 1/4 UNC

Plugs

Description	Threaded cable joint	Body colour coding	Figures switching	Order no.
Plug DIN 43650, design type AF, protection class IP 65 Voltages up to 250 V	PG 9	black, B grey, A	Fig. 1	5001710 5001711
	PG11	black, B grey, A	Fig. 1	5001716 5001717

Fig. 1

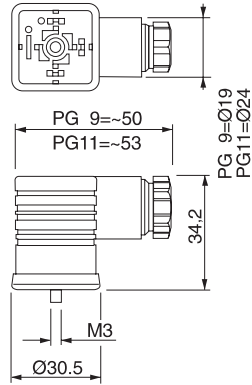

Other plugs on request

